

BENCHMARK MEDIA SYSTEMS, INC.

DOA-2 and 3 Instruction Manual

1.0 Introduction.....	1
2.0 General Features	1
3.0 Unpacking and Installation.....	1
3.1 Physical Installation	1
3.2 Electrical Installation.....	2
3.2.1 Power Connections.....	2
3.2.2 Input and Output Connections.....	3
3.2.3 Output Impedance.....	3
3.2.4 Balanced or Single Ended Outputs.....	4
3.2.5 Terminations and Output Amplitude.....	4
3.2.6 Gain Control	5
3.2.7 Remote Installation of the Gain Control.....	5
4.0 Troubleshooting and Repair	5
4.1 Soldering Technique.....	6
4.2 Circuit Board Re-Soldering.....	6
5.0 Electrical Schematic.....	7
6.0 Component Assembly	8

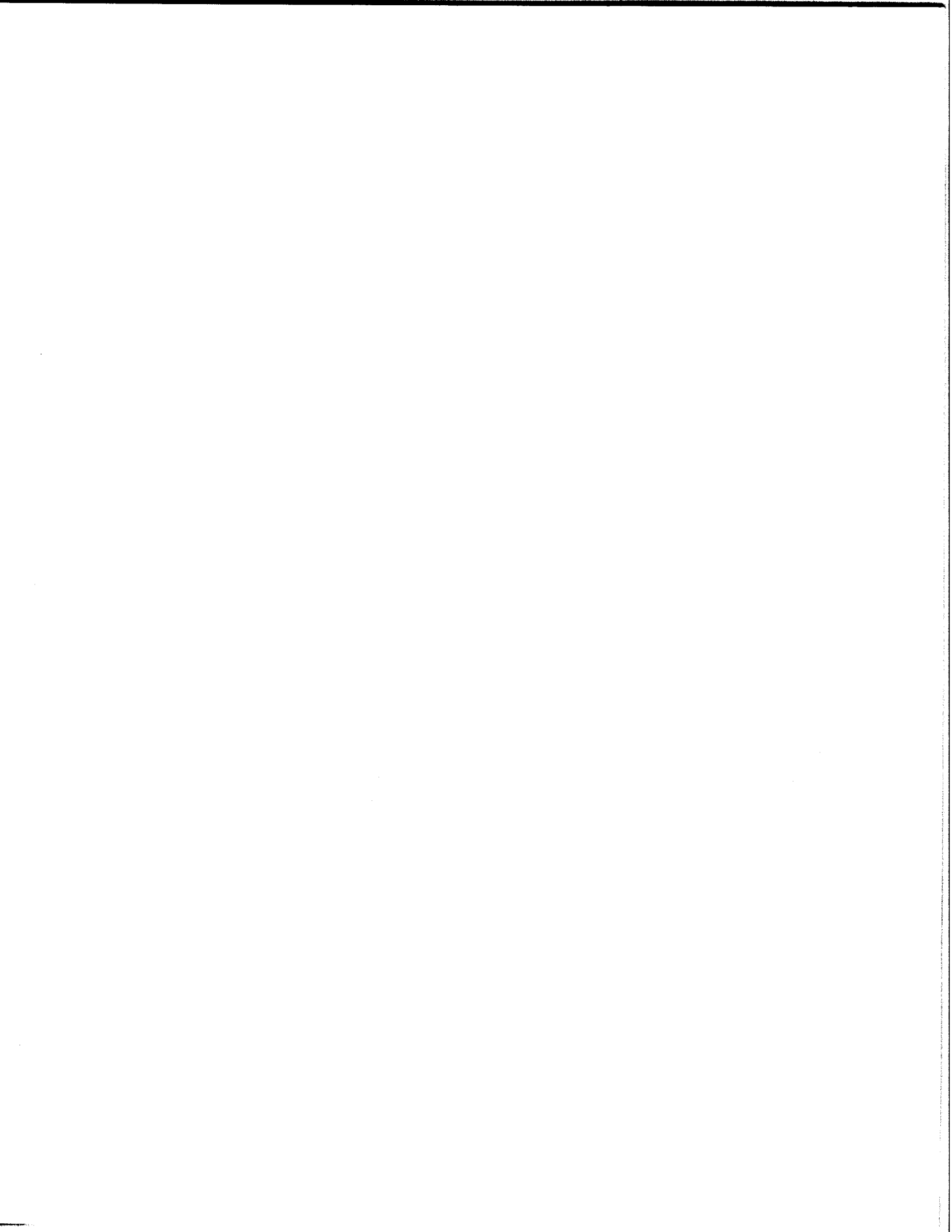

BENCHMARK MEDIA SYSTEMS, INC.

DOA-2 and 3 Instruction Manual

1.0 Introduction

The DOA-2 & 3 Differential Output Amplifiers are universal output devices designed to provide both a balanced output and the gain necessary to interface consumer and semi-professional audio equipment to the professional environment.

2.0 General Features

The DOA-2 & 3 balanced output devices have variable gain from full Off to +26 dB, an output impedance of 60 Ω , and an input impedance that varies with the amplification factor that is used (100 k Ω max, 10 k Ω min.) The DOA-3 is for use with bipolar power supplies, while the DOA-2 is for use with a single positive power supply. The DOA-2 and 3s have AC coupled output stages. The DOA-3 satisfies the need for a bipolar powered device that allows continuously adjustable output level without the problem of continuously changing DC offset voltage. All circuitry is on small printed circuit boards that is mounted on a Neutrik XLR type connector. The operational amplifier used is a NE5532 for outstanding audio performance.

3.0 Unpacking and Installation

As with any delicate electronic equipment, care must be exercised in the handling of the circuit board. Carefully unpack the DOA-2 or 3 and place it on the work table for installation in the intended host equipment. Care has been taken during packing to assure the withstanding of normal shipping conditions. Examine the device carefully as it is unpacked. If the shipping carton is damaged, check the equipment immediately and notify the carrier and Benchmark if there is damage to the module.

3.1 Physical Installation

The appropriate holes must be drilled or punched in the equipment chassis intended to receive the DOA.

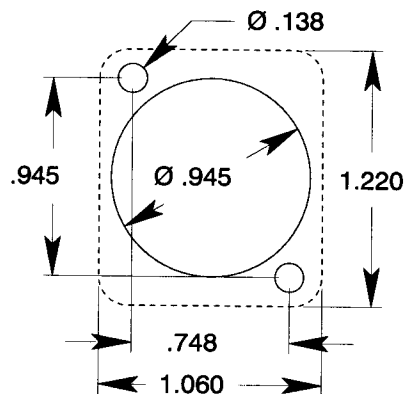

Fig 3.1 Neutrik "D" Series Panel Layout

Figure 3.1 shows the drill pattern for the Neutrik connector. Drill the appropriate holes and mount the DOA-2 or 3.

3.2 Electrical Installation

The DOA-3 must be powered from bipolar supplies. The power voltage range is from ± 9 to ± 24 volts. A group of three pins at the rear of the DOA-3 are used to bring power into the device. See figure 3.2 for the correct pin assignments.

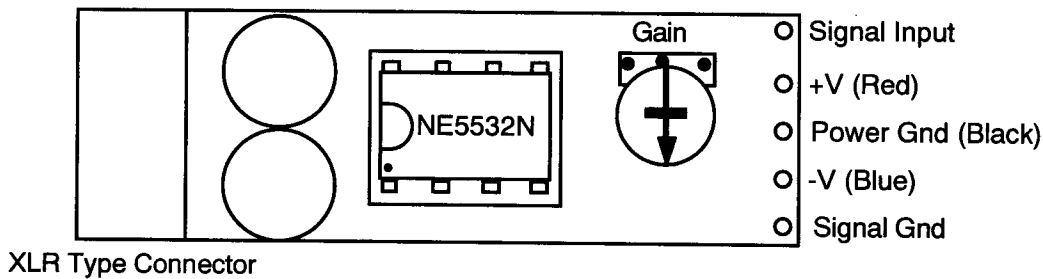

Fig 3.2 DOA-3 Connections and Controls

The DOA-2 must be powered from a single positive supply. The power voltage range is from +18 to +44 volts. Two pins at the rear of the DOA-2 are used to bring power into the device. A red wire needs to be connected to the supply's positive terminal and a black wire to the supply's negative terminal. See figure 3.3 for the correct pin assignments.

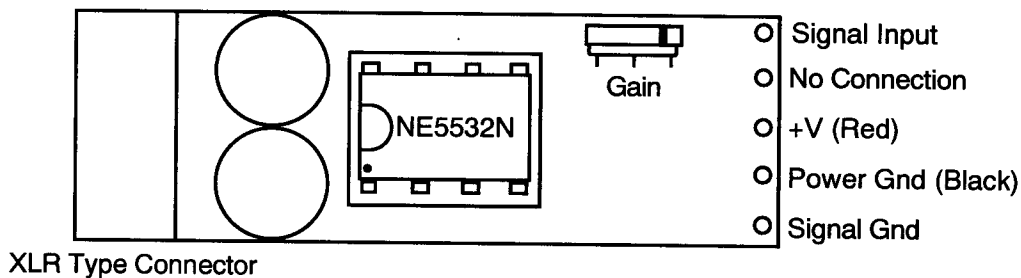

Fig 3.3 DOA-2 Connections and Controls

Input and power connections are made at the right end of the board as shown in the diagrams. A mating 0.025" square post connector is provided to solder to with signal and power wires.

3.2.1 Power Connections

Use the highest power supply voltage possible within the constraints of the op-amp limits. Often within a piece of equipment you will find both unregulated voltages of ± 15 to ± 18 volts as well as ± 9 to ± 12 volts regulated (+30 and +24 respectively for the DOA-2). It is sometimes possible to use the "raw" DC voltages, provided the ripple content is quite low, to power the DOA-2 or 3. But since the NE5532 does not have good power supply rejection at high frequencies, caution must be exercised when doing this. Using the highest voltage available will give the best headroom, but high ripple and noise content will most likely degrade the signal to noise ratio. Use this method only if you can measure the results of your work.

The maximum power supply voltage allowed by the manufacturer of the op-amp is ± 22 volts (+44 for the DOA-2). ± 18 (+36) volts, however, will provide cooler device operation. The use of ± 22 (+44) V supply voltages results in an increase in quiescent current drawn by

the op-amps. The resultant heating of the chip increases the input bias currents. As the chip gets hot, the output current limit point is reduced, and if the device actually should have a 600 Ω load (*not* recommended) the maximum output capability is actually LOWER than if the power supply voltage were at ± 18 volts. On the other hand some audio equipment uses ± 24 (+48) volt power supplies, and it is desirable to maintain the same output *voltage* capability with the addition of the differential output amplifiers. It is our experience that the NE5532 will work reliably with these limits even though they are beyond the specification given by the manufacturer, provided the op-amp output feeds a bridging input. The chip will, however, run *very* warm (read HOT) to the touch.

3.2.2 Input and Output Connections

!!! Warning !!!

The DOA-2 & 3 are constructed on single sided printed circuit boards that may be easily damaged by excessive heat while soldering. It is very easy to "lift" a run from the board. Therefore extreme caution must be exercised during the soldering process. We strongly recommend the use of a temperature controlled soldering station, set for 600°F. See the section on soldering in the Troubleshooting and Repair section 4.0

Make sure that there is no significant DC, beyond 20 mV, coming from the output of the equipment that will feed the input to the DOA-3. There is no input coupling capacitor on the DOA-3 and any amplified DC will reduce the headroom of the amplifier. Also, DC on the input presents the possibility of a polarity inversion across the output coupling capacitors.

The DOA-2 will not be affected by small DC voltages at the output of the equipment.

3.2.3 Output Impedance

The output impedance of the DOAs is 60 Ω balanced, 30 Ω unbalanced. This is achieved with 1% metal film build-out resistors. A 60 Ω output impedance has been found to be the optimum drive Z for today's foil shielded cables. This allows the longest possible cable runs to be made without excessive high frequency roll-off and without significant high frequency response peaking.

If the shielded pair being used has 32 pF/foot capacitance between conductors, then for a system high frequency cutoff of say 30 kHz, the maximum length of cable that may be used is 2947 feet, or approximately 900 meters. This is ten times the length possible, under the same constraints, if the output impedance were 600 Ω , with a bridging input.

The total C is determined by:

$$C = \frac{1}{2 \pi f_c R} \quad [3.1]$$

C = maximum allowable cable capacitance (total)

R = output impedance (60 Ω)

f_c = lowest system high frequency cutoff tolerable

Obviously, using low capacitance cable will further improve the limits.

The total number of feet of whatever cable chosen is found by:

$$\text{Feet}_{\max} = \frac{C}{\text{Cable pF/ft}} \quad [3.2]$$

Using the DOA-2 or 3, the maximum cable length that may be driven, from the standpoint of available current (40 mA peak) to feed the cable capacitance, is approximately 300' at 32 pF/foot. Belden 9700 series, a foil shielded data transmission cable line, at 12 pF/foot, and Mogami 2574 at 6 pF/foot allow proportionally longer lines to be driven. See "A Clean Audio Installation Guide" by Allen H. Burdick, A Benchmark Media Systems application note.

3.2.4 Balanced or Single Ended Outputs

The DOA-2 or 3 can be used either as balanced or a single ended output driver. When used as a balanced output device, both of the outputs, inverting and non-inverting will, of course, be utilized. When used as a single ended output for its gain capability only, be sure *only one* of the two outputs is utilized, either the inverting or the noninverting. Under no circumstances should an output be tied to ground as would be done with a transformer output. Unlike transformer type outputs, the active balanced output is already ground referenced.

!!! Warning !!!

Tying one of the outputs legs to ground will cause a large amount of distortion to occur as well as overheating of the operational amplifier.

3.2.5 Terminations and Output Amplitude

As indicated, the impedance matched audio interconnect system is now passé for anything but *extremely* long cable runs. With modern operational amplifier technology it is no longer necessary nor even desirable to terminate audio lines with a "matched" low impedance, unless you are the Phone Co. with miles of cable, the length of which is over 1/10 wavelength at the highest frequency of interest, i.e. 3000 - 5000' at 20 kHz.

Today the voltage sourced interconnect system is becoming universal. The voltage sourced system features a low source impedance of approximately 50 Ω to 60 Ω , and a high input impedance of 10 k Ω or higher. The advantages are:

1. Much less power drawn from the source equipment, therefore less heat generated.
2. Lower distortion generated by the output stage doing the driving.
3. 14 dB lower noise pickup by the interconnect lines due to the lower source impedance.

The DOA-2 & 3 were designed with this in mind and while they will drive a 600 Ω load, they do so with reduced headroom (lower clip amplitude) due to the internal current limiting of the op-amp used. Additionally, there is a significant increase in distortion generated by the operational amplifier. Therefore, for the best headroom and system

performance, DON'T put a 600 Ω resistor at the receiving end of the cable being driven by either the DOA-2 or 3. The only exception to this might be in a high RF environment, where the resistor could tame the line in terms of RF power.

PS Voltage & Quies I	Max Out Unterm.	Max out 600 Ω Term.
+44 or ± 22 V @ ± 12.0 mA	+30 dBu	Op-amp overheats
+36 or ± 18 V @ ± 9.50 mA	+28 dBu	+26 dBu
+30 or ± 15 V @ ± 8.60 mA	+26 dBu	+25 dBu
+24 or ± 12 V @ ± 7.75 mA	+24 dBu	+23 dBu
+20 or ± 10 V @ ± 7.50 mA	+22 dBu	+21 dBu
+18 or ± 09 V @ ± 7.50 mA	+21 dBu	+20 dBu

Fig 3.3 DOA Output Limits and Quiescent Current

The maximum output from the DOA operating as an *unbalanced* output is always 6 dB lower (1/2 the voltage available) than when operating as a balanced output.

3.2.6 Gain Control

The gain of the DOA-2 & 3 is adjustable from full Off to +26 dB balanced or +20 dB unbalanced. Because these devices use the potentiometer within the feedback loop of the amplifier, optimum signal to noise ratio is always maintained. This is because only the amplification necessary to perform the task is asked of the op-amps. The output noise at maximum amplification is -85 dBu and at minimum amplification is -105 dBu. 0 dBu is equal to 0.7746 volts RMS. Therefore, at the manufacturer's recommended maximum power supply voltage of ± 22 volts and at *maximum* amplification, the dynamic range of the DOAs is 115 dB (-85 dBu to +30 dBu). Worst case (minimum power voltage of ± 9 volts) the dynamic range is -85 dBu to +21 dBu = 106 dB. Best case performance, at unity gain or less, yields a total dynamic range of 130 dB.

3.2.7 Remote Installation of the Gain Control

The on board potentiometers of the DOA-2 and DOA-3 may be removed and 100 k Ω linear taper panel potentiometer potentiometers may be substituted. The principal thing to be remembered is that the summing node of the amplifier is one on these leads and needs to be kept as short as possible to avoid hum pickup. Twisting the wires will aid somewhat in hum rejection.

4.0 Troubleshooting and Repair

The DOA-2 & 3 are carefully constructed of very high quality components, thoroughly tested before shipment and therefore will probably never need servicing. Should a problem occur with your device, the following will aid in locating the problem.

The first step in troubleshooting, is to check for mechanical problems that may have occurred during the installation. Many problems may be solved by close visual inspection. We heartily recommend the use of an "OptiVISOR", manufactured by Donegan Optical Co., or equivalent stereo optical magnifier.

If inspection reveals no mechanical problems, the DC operating voltages should be checked. First determine that the proper power voltages exist at pins 4 and 8 of the operational amplifier. With the DOA-3 a positive (the plus supply) voltage, referenced to ground, at pin 8 should be present. Likewise a negative (the negative supply) voltage at

pin 4 should be present. In the case of the DOA-2, pin 4 is ground and pin 8 should have the full power voltage present. The output pins of the amplifier should be checked next, that is, pins 1 and 7 on both devices. These measurements should be made with no audio signal present. The DOA-2 should have a voltage that is nearly one half that of the power voltage, present at both outputs. The DOA-3 will have a DC offset voltage that is dependent upon the gain of the amplifier, but in any case should be less than 0.2 volts either positive or negative. If the output voltages are not correct, under no signal conditions, the replacement of the operational amplifier will in most cases fix the device.

On extremely rare occasions a faulty passive component may exist. If you are unable to locate the problem, troubleshooting assistance is available, via telephone, from the Customer Service Department at Benchmark Media Systems.

4.1 Soldering Technique

Printed circuit boards are *very* easy to damage by excessive heat. Unless you have developed the specialized skills necessary to remove and replace components, we suggest that you leave the task to someone skilled in these techniques.

When servicing printed circuit boards we strongly recommend the use of a vacuum desoldering station, such as the Hakko 470. The proper technique with these stations is to apply the tip to the area to be de-soldered and wait for the solder to thoroughly melt. When the solder has become liquid, apply the vacuum while moving the hollow tip with the component lead in a circular motion. By rotating the lead, with the tip against the board, but *without* applying pressure to the pad, you are able to most thoroughly remove the solder. In turn the component will often drop out of the circuit board when you are finished.

4.2 Circuit Board Re-Soldering

NASA has developed an effective technique that ensures highly reliable solder joints. It involves first heating the component lead, since it usually has the higher mass, by applying a small amount of solder to the tip of the soldering iron at almost the same time as you apply the iron to the component lead. This will allow some flux to make it to the component lead. The iron should be approximately 1/8" above the board. When the lead has come up to temperature so that it melts the solder when placed against it and has good wetting, slide the soldering iron down the lead and heat the printed circuit board pad while applying a controlled amount of solder to the joint. All of this should take no more than a couple of seconds. If the component that is to be installed has leads that are oxidized, it will be necessary to clean them. This may be done with either a Scotch Bright® abrasive pad or fine bristle fiberglass brush, among other methods.

This completes the DOA-2 & 3 instruction manual.

Ed. 2 May 1994

Benchmark Media Systems Inc.
5925 Court Street Road Syracuse, NY 13206-1707
(315) 437-6300 FAX (315) 437-8119

REVISIONS

A SEE DCN NO. 49

12/20/88

J.R.P.

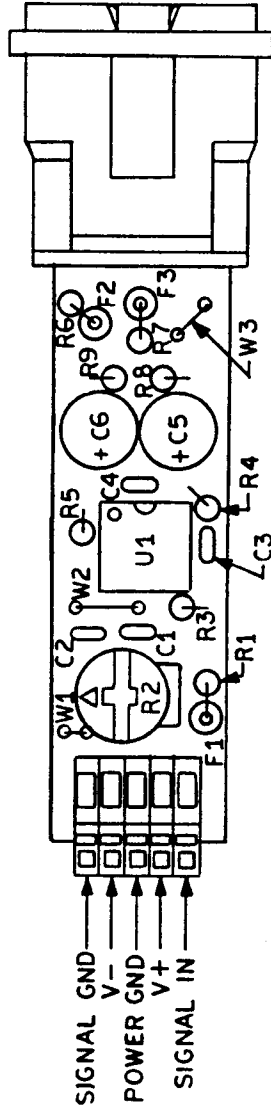

Benchmark Media Systems

DOA-3

SCALE

CHECKED BY

DRAWN BY J.R.P.

DATE 2/11/88

M. H. Longnick

SIZE B

COMP ASS'Y

DRAWING NO. 250033