

MPS-400 and MPS-420 Instruction Manual

Contents

MPS-400 and MPS-420 Instruction Manual	1
Contents	1
1.0 General	1
1.1 MPS-400 Description	1
1.2 MPS-420 Description	1
2.0 Unpacking.....	2
2.1 Equipment List.....	2
3.0 Specifications.....	2
3.1 MPS-400 Specifications	2
3.1.1 MP-4 Microphone Preamplifier.....	2
3.2 MPS-420 Specifications	3
3.2.1 MP-4 Microphone Preamplifier.....	3
3.2.2 DOM-3 Differential Output Mixer	4
3.2.3 HPA-1 Stereo Headphone Amplifier.....	4
3.3 PS-10B Power Supply Specifications.....	5
4.0 Installation	5
4.1 Introduction.....	5
4.2 Mechanical.....	5
4.3 Wiring.....	5
4.3.1 Power Supply Connections	6
4.3.2 Audio Connections.....	7
5.0 Operation	8
5.1 General Operation	9
5.1.1 Location Recording and Magnetic Fields.....	9
5.1.2 Phantom Power “Warm Up”	9
5.1.3 Panning of a 3rd Microphone	9
5.1.4 Setting Levels	9
5.2 Discussion of Noise and Microphone Performance	10
5.2.1 Noise Primer.....	10
5.2.2 Electro-Voice RE-20 Microphone.....	10
5.2.3 Sennheiser MKH-40-P48.....	11
5.2.4 Miscellaneous	12
5.3 MPS-400 and MPS-420 Preamplifier Operation.....	12
5.3.1 General	13
5.3.2 Differential Converter	13
5.3.3 Input Stage.....	13
5.3.4 Output Stage.....	14
5.3.5 Measurement Curves	15
5.4 MPS-420 Additional Features	17
5.4.1 DOM-3 Operation.....	17
5.4.1.1 DOM-3 Balanced or Single Ended Outputs.....	17
5.4.1.2 DOM-3 Terminations and Output Amplitude.....	18
5.4.2 HPA-1 Operation.....	18
6.0 Servicing.....	20
6.1 Soldering Technique.....	20
6.2 HPA-1 Troubleshooting.....	21

1.0 General

This manual contains all information necessary to install and operate the MPS-400 and MPS-420 Microphone Preamplifier Systems.

The MPS-400 and MPS-420 systems were designed to achieve the highest performance available in microphone pre-amplification. The MPS-400 and MPS-420 are ideal for the recordist that wants to maximize performance for analog or digital recorders using the superior microphone technologies that are emerging. With the MPS-400 and MPS-420 at or close to the microphone, additional performance benefits are realized as opposed to long mic cable runs to a console or recorder. By immediately raising the microphone signal amplitude to the nominal system reference amplitude, minimum interference is allowed to enter the system from power lines, SCR stage lighting, etc. Longer lines may also be driven from the standpoint of system response. The line level output of the MPS-400 and MPS-420 systems may be used with an existing mic input at a console by using an attenuator at the console input, such as the LMA-1.

In addition to its obvious use as a microphone preamplifier, the MPS-400 and MPS-420 may be used anywhere amplification of 20 dB or more is needed and minimum noise is desired. One application which is finding increased acceptance is using the system to bring up low telco levels without adversely effecting the noise floor. In fact with the overall amplification range of -2 to +70 dB and input clip point equal to the output clip point minus the amplification, the MPS-400 and MPS-420 become universal gain blocks with performance that is nearly perfect.

The following is a brief description of each system.

1.1 MPS-400 Description

The MPS-400 Microphone Input Preamplifier System consists of four MP-4 Microphone Preamplifier Cards installed in a 19" wide rack mount chassis. The chassis is fabricated of high quality extruded aluminum with Lexan® front and rear panels. System height is one rack unit (1RU = 1.75").

Controls for all four channels are located on the front panel. Each channel has a variable gain control, 20 dB attenuator switch and a +48 V phantom power switch.

The rear panel contains eight XLR type connectors for audio inputs and outputs for all four channels. A locking four pin XLR type receptacle is also provided for the external power supply connection.

1.2 MPS-420 Description

The MPS-420 Microphone Input Preamplifier System consists of four MP-4 Microphone Preamplifier Cards, two DOM-3 Differential Output Mixer units and one HPA-1 Stereo Headphone Amplifier (Monitor) installed in a 19" wide rack mount chassis. The chassis is fabricated from high quality extruded aluminum with Lexan® front and rear panels. System height is one rack unit (1RU = 1.75").

Controls for all four channels and the Monitor are located on the front panel. Each channel has a variable gain control, 20 dB attenuator switch and a phantom power switch. The Monitor controls include a TRS jack for headphones and a gain control.

The rear panel contains eight XLR type connectors for audio inputs and outputs for all four channels. Two additional XLR type connectors are provided for Left and Right mixed outputs. A locking four pin XLR type receptacle is also provided for the external power supply connection.

2.0 Unpacking

Care has been taken during packing the MPS-400, MPS-420 system to assure it will withstand normal shipping conditions. Examine the equipment carefully as it is unpacked. If the shipping carton appears to have been damaged during shipment check the equipment and notify the carrier and Benchmark immediately if there are signs of damage.

2.1 Equipment List

The following is a list of equipment and accessories provided with the MPS-400 or MPS-420 system. Check the list to assure all items have been received.

<u>Qty.</u>	<u>Item</u>
1	MPS-400 Microphone Input Preamp Unit or MPS-420 Microphone Input Preamp Unit
1	PS-10B Power Supply (multiple systems can use the PS-102PH or PS-202PH)
2	Rack Adapters with attaching screws (4).
4	#10-32 Rack Mounting Screws with plastic washers
4	Rubber Feet for desk top use.
1	Installation Manual

3.0 Specifications

The following is a list of specifications for the MPS-400 and MPS-420 Microphone Input Amplifier System.

3.1 MPS-400 Specifications

The MPS-400 Microphone Input Preamp System consists of four MP-4 Microphone Preamp Cards designed to perform to the following specifications.

3.1.1 MP-4 Microphone Preamp

GAIN RANGE: Continuously adjustable from +18 to +70 dB. With the use of the 20 dB pad the overall gain range is -2 to +70 dB.

FREQUENCY RESPONSE: High Frequency response, for any gain: -3 dB greater than 200 kHz; Low frequency response, dependent upon gain: worst case @ A=70 dB the -3 dB point is 26 Hz, @ A=40 dB the -3 dB point is 0.85 Hz.

THD: At a gain of 40 dB, the T.H.D. @ 2 kHz is 0.0006%, and @ 20 kHz is 0.0009%. All electrolytics are paralleled with large film capacitors.

NOISE FLOOR: For all gains up to 36 dB the output noise is -93 dBu. Above that a one dB noise figure will apply, i.e. for a gain of 60 dB the output noise would be approximately -69.5 dBu, referenced to 150 Ω over a 20 kHz. bandwidth.

MAXIMUM OUTPUT LEVEL: Balanced out with ± 15 volt supplies = +27 dBu; Unbalanced outputs = +21 dBu.

INPUT IMPEDANCE: 8 K Ω in parallel with 760 pF, 1.47 K Ω in parallel with 25 pF when the attenuator is inserted (balanced).

LOAD IMPEDANCE: The recommended load impedance for the MP-4 is 2 k Ω or greater. While the unit will drive a 600 Ω load to a reasonable output level (+25 dBu) it does so with reduced performance and is *not* recommended.

OUTPUT IMPEDANCE: 60 Ω balanced; 30 Ω unbalanced.

R.F. PROTECTION: The MP-4 incorporates a two pole common mode filter that limits common mode bandwidth to 26 kHz, with no degradation in noise performance. As a result, R.F. is down 60 dB at 1 MHz, while allowing the differential bandwidth to be greater than 200 kHz.

3.2 MPS-420 Specifications

The MPS-420 Microphone Input Preamplifier System consists of four MP-4 Microphone Preamplifier Cards, two DOM-3 Differential Output Mixer units and one HPA-1 Stereo Headphone Amplifier (Monitor) designed to perform to the following specifications.

3.2.1 MP-4 Microphone Preamplifier

GAIN RANGE: Continuously adjustable from +18 to +70 dB. With the use of the 20 dB pad the overall gain range is -2 to +70 dB.

FREQUENCY RESPONSE: High Frequency response, for any gain: -3 dB greater than 200 kHz; Low frequency response, dependent upon gain: worst case @ A=70 dB the -3 dB point is 26 Hz, @ A=40 dB the -3 dB point is 0.85 Hz.

THD: At a gain of 40 dB, the T.H.D. @ 2 kHz is 0.0006%, and @ 20 kHz is 0.0009%. All electrolytics are paralleled with large film capacitors.

NOISE FLOOR: For all gains up to 36 dB the output noise is -93 dBu. Above that a one dB noise figure begins to apply, i.e. for a gain of 60 dB the output noise would be approximately -69.5 dBu, referenced to 150 Ω over a 20 kHz bandwidth.

MAXIMUM OUTPUT LEVEL: Balanced out with ± 15 volt supplies = +27 dBu; Unbalanced outputs = +21 dBu.

INPUT IMPEDANCE: 8 K Ω in parallel with 760 pF, 1.47 K Ω in parallel with 25 pF when pad is inserted (balanced).

LOAD IMPEDANCE: The recommended load impedance for the MP-4 is 2 k Ω or greater. While the MP-4 will drive a 600 Ω load to a reasonable output level (+25 dBu) it does so with reduced performance and is *not* recommended.

OUTPUT IMPEDANCE: 60 Ω balanced; 30 Ω unbalanced.

R.F. PROTECTION: The MP-4 incorporates a two pole common mode filter that limits common mode bandwidth to 26 kHz, with no degradation in noise performance. As a result, R.F. is down 60 dB at 1 MHz, while allowing the differential bandwidth to be greater than 200 kHz.

3.2.2 DOM-3 Differential Output Mixer

GAIN RANGE: Full OFF to +12 dB. Set at -3 dB in the MPS-420.

INPUT IMPEDANCE: 10K Ω each input.

LOAD IMPEDANCE: The recommended load impedance for the DOM-3 is 2 k Ω or greater. While the DOM-3 will drive a 600 Ω load to a reasonable output level (+25 dBu) it does so with reduced performance and is not recommended.

OUTPUT IMPEDANCE: 60 Ω balanced; 30 Ω unbalanced.

MIXED OUTPUT LEVEL: 3 dB lower than input level (factory set).

THD: 0.001% at unity gain & 2 kHz, 0.002% at unity gain & 20 kHz.

3.2.3 HPA-1 Stereo Headphone Amplifier

INPUTS: One stereo (10K Ω Min) unbalanced.

OUTPUT: Stereo, for use with Ring/Tip/Sleeve plugs only.

OUTPUT IMPEDANCE: 30 Ω .

LOAD IMPEDANCE: 60 to 600 Ω .

OUTPUT LEVEL: Up to +21 dBu into 600 Ω .

OUTPUT CONTROL: Dual 100K Ω linear taper pot.

BANDWIDTH: DC to 50 kHz min.

NOISE FLOOR: Better than -90 dBu at maximum gain.

POWER REQUIREMENTS: ± 15 VDC @ 26 mA. quiescent ; @ 145 mA. peak at peak output (200 Ω headphone); @ 75 mA. peak at peak output (600 Ω headphone).

3.3 PS-10B Power Supply Specifications

INPUT VOLTAGE: 105-125 VAC, 50-60 Hz, single phase; 220-240 VAC with internal strap change.

OUTPUT VOLTAGE: ± 18 VDC @ 300 mA.; +48 VDC @ 50 mA. max.

4.0 Installation

Prior to starting the installation it is recommended that "A Clean Audio Installation Guide" by Allen H. Burdick be read and applied to the installation. This document is included in this manual and presents installation techniques necessary to achieve the capabilities designed into the system.

4.1 Introduction

If the MPS-400 or MPS-420 is to be mounted in a 19" wide equipment cabinet, determine the location. Also choose a location within the cabinet for the PS-10B Power Supply. The power supply should be mounted on a shelf or other suitable place within a distance of 2 to 3 ft. from the rear of the MPS-400, MPS-420 chassis.

As with all highly sensitive amplifier systems, it is possible for electro-magnetic fields to be coupled to the electronics to the detriment of its operation. It is important to locate the amplifier system away from equipment that has power transformers, particularly power amplifiers. Listening to the output of the system without microphones, but with the pads engaged, under full gain will allow you to determine the presence of any magnetic field pickup. The location of the equipment packages in an equipment rack may have to be re-adjusted to isolate the preamplifier system from such fields.

4.2 Mechanical

Remove the Rack Adapters and four attaching screws from the plastic packet. Position the Rack Adapters one on each side of the front corner of the MPS-400, MPS-420 chassis. Attach the Rack Adapters to the MPS-400, MPS-420 chassis using the four screws provided.

Remove the four #10-32 mounting screws from the plastic packet. Check to assure that the plastic flat washers provided with the screws are in place under the screw heads. Place the MPS-400, MPS-420 into the equipment cabinet from the front. Secure the MPS-400, MPS-420 Rack Adapters to the equipment cabinet rack utilizing the #10-32 mounting screws.

Alternately, mount the rubber feet to the bottom of the MPS-400, MPS-420 chassis near the four corners of the system for use on a desk top.

Install the PS-10B Power Supply in the previously selected location. Do *not* plug the Power Supply power cord into the 120 VAC power outlet at this time.

4.3 Wiring

When wiring the audio connections to the MPS-400 or MPS-420 follow the recommendations in "A Clean Audio Installation Guide". Figure 1 shows the connector locations on the rear panel of the MPS-400. Figure 2 shows the connector locations on the rear panel of the MPS-420.

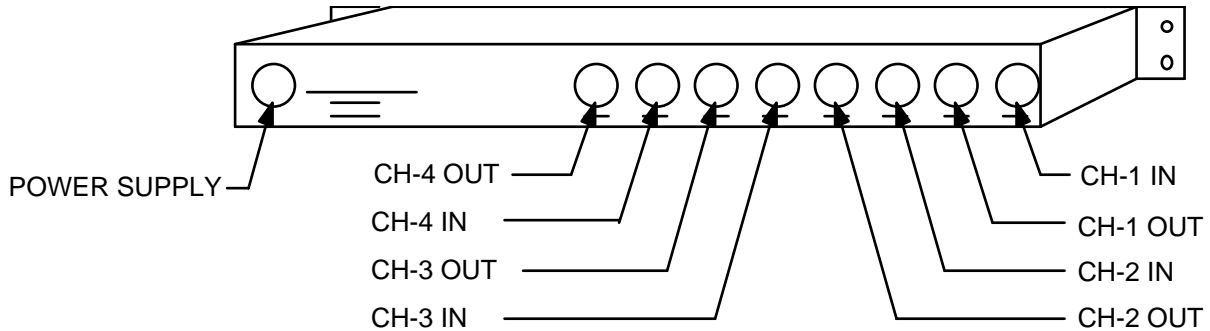

Figure 1 - MPS-400 Rear View

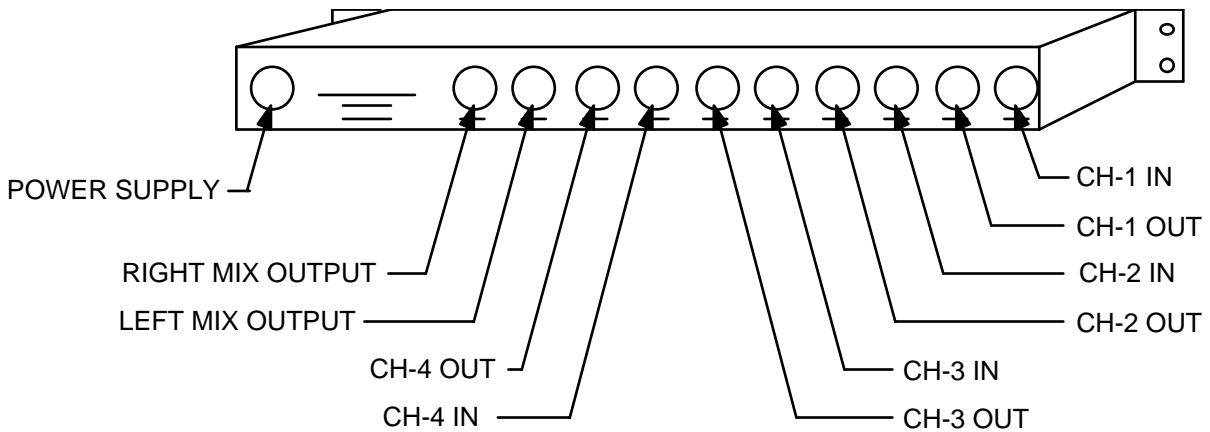

Figure 2 - MPS-420 Rear View

4.3.1 Power Supply Connections

Connect the PS-10B Power Supply cable to the power supply input connector located on the rear of the MPS-400, MPS-420 chassis.

PS-102PH or redundant PS-202PH power supplies are available from the factory to power up to 10 MPS-400's or MPS-420's installed in the same rack. The PS-102 is three rack units (5.25") tall, 16" deep and requires an additional 4" of depth for connector clearance. Check with the factory concerning the possible financial advantages of this configuration.

If other external power sources are to be used, care must be taken in the installation of the MPS-400 or MPS-420 to prevent stray electromagnetic fields from effecting the noise floor of the preamps. For example, since magnetic leakage from a power transformer can cause problems, Benchmark recommends the use of a toroidal power transformer with its inherent low leakage. Additionally, mu-metal shielding may be needed to prevent magnetic coupling. Using outboard power supplies or battery power where possible will eliminate internally generated EMI. Battery power can also eliminate ground loop induced hum, however, a quality battery of adequate capacity would be required to operate the MPS-400 or MPS-420.

The power requirements for the MPS-400 and MPS-420 are a bipolar power supply with output voltages of ± 12 VDC to ± 22 VDC. This supply should be well regulated with low ripple and noise and should be capable of the appropriate load current. Additionally, if phantom power is to be used with condenser microphones, then a +48 VDC supply will be needed. Again, it will need to be a supply with low ripple and noise, capable of the appropriate load current. The power supply ground is common for both the low voltage \pm supply and the high voltage phantom supply.

Figure 3 provides information relative to the external power supply connector pin number assignments for the MPS-400 and MPS-420.

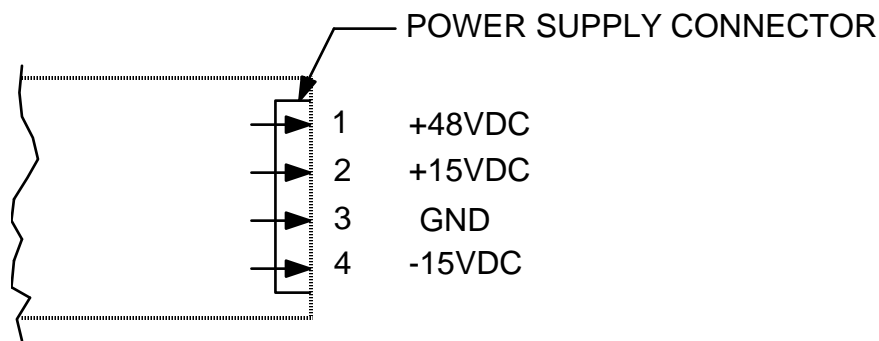

Figure 3 - MPS-400 and MPS-420 External Power Supply Connector

4.3.2 Audio Connections

The recommended load impedance for the MPS-400 or MPS-420 is 2 k Ω or greater. While the MP-4 cards and the DOM-3s will drive a 600 Ω load to a reasonable output level (+25 dBu) they do so with reduced performance and this is not recommended. Also the additional current requirements reduce the amount of current available to drive cable capacitance and in the case of the MPS-420, the amount of current available to the headphone amplifier.

When using the MPS-400 or MPS-420 with either unbalanced outputs or unbalanced inputs, it is *imperative* that the device be wired correctly. The inputs and outputs of the MPS-400 and MPS-420 are transformer-less for maximum performance. Therefore, if the outputs of the MPS-400 and MPS-420 are not wired correctly (with the black wire unused) it is quite possible to short one of the output amplifiers and cause severe distortion from the MP-4's.

Figures 4 and 5 below illustrate the correct way to wire the connectors for proper operation:

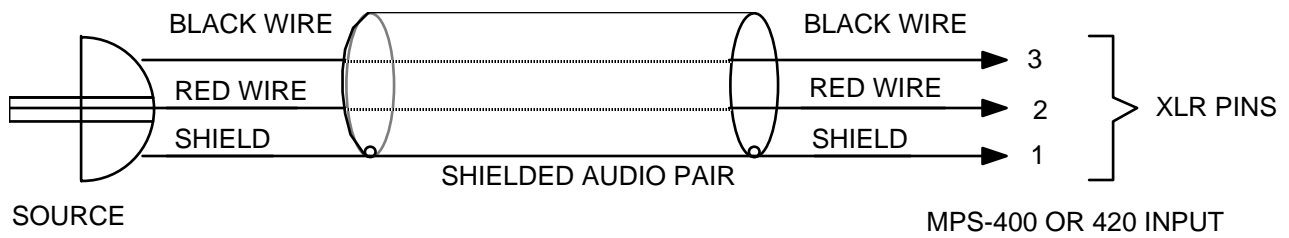

Figure 4 - Unbalanced Output to MPS-400 or MPS-420 Input

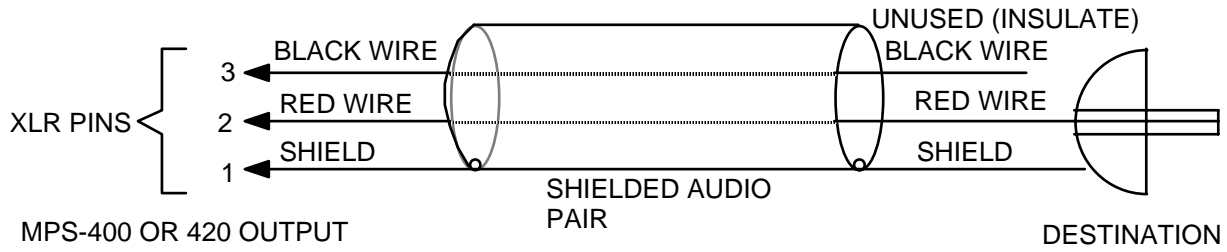

Figure 5 - MPS-400 or MPS-420 Output to Unbalanced Input

5.0 Operation

This section provides a detailed description of the operation of the MPS-400 and MPS-420 Microphone Input Pre-amplifier Systems. Figure 6 shows the control locations on the front panel of the MPS-400. Figure 7 shows the control locations on the front panel of the MPS-420.

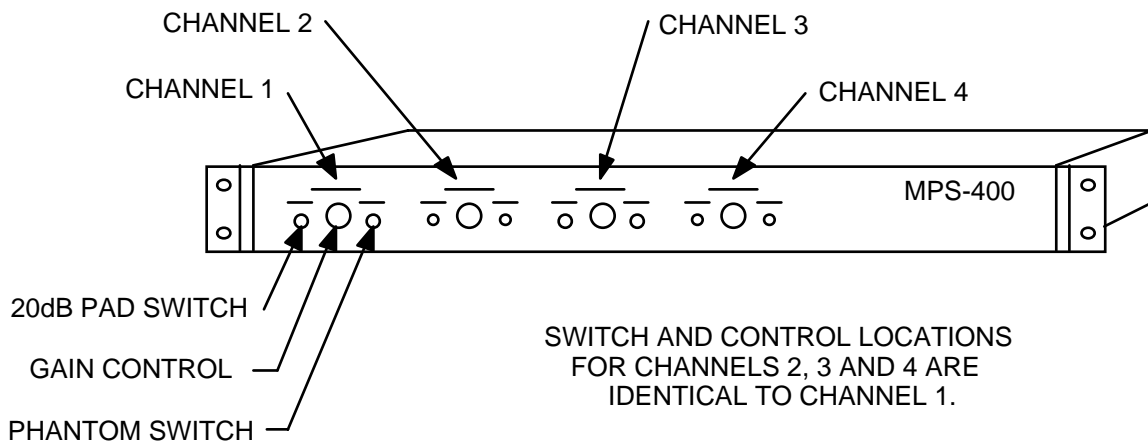

Figure 6 - MPS-400 Front View

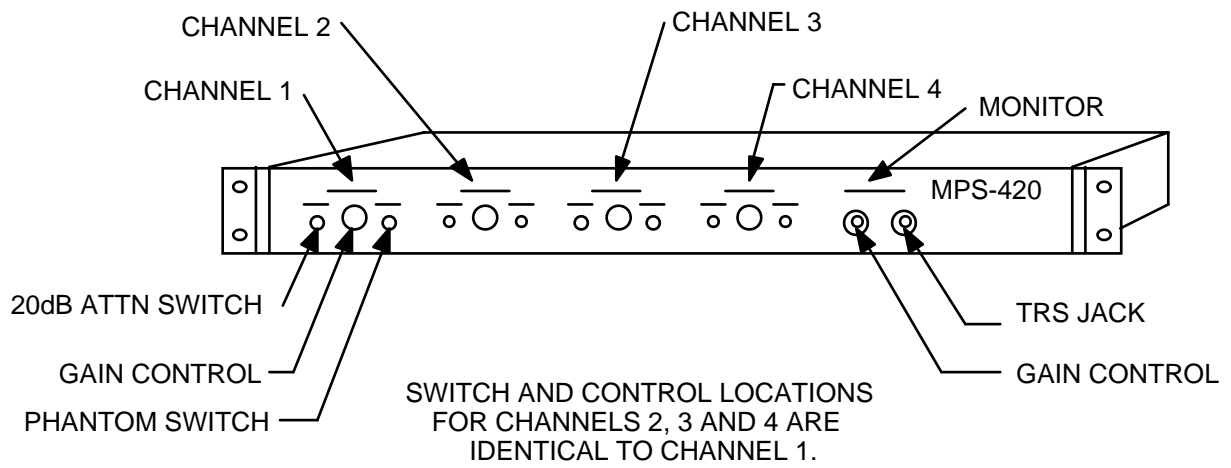

Figure 7 - MPS-420 Front View

5.1 General Operation

The operation of the MPS-400 and MPS-420 is generally intuitive. However the following items may not be immediately apparent.

5.1.1 Location Recording and Magnetic Fields

As mentioned discussed above, all highly sensitive amplifier systems can be effected by electro-magnetic fields, that is they may be coupled to the electronics to the detriment of the recording. It is important to locate the amplifier system away from equipment that has power transformers, particularly power amplifiers. Listening to the output of the system without microphones, but with the pads engaged, under full gain will allow you to determine the presence of any magnetic field pickup. If the MPS-400 or MPS-400, MPS-420x4+ is located in an equipment rack, the location of the equipment packages may have to be re-adjusted to isolate the preamplifier system from such fields.

5.1.2 Phantom Power “Warm Up”

While you may never notice the problem, if Phantom power is to be used, the phantom power switch should be turned on approximately one hour, if possible, before the use of the system. This minimizes the possibility of noise in the system, allowing the proper formation of the phantom power coupling capacitors dielectric. This in turn ensures no DC leakage currents, the source of noise in capacitors.

5.1.3 Panning of a 3rd Microphone

Pan pots are not included within the MPS-420, however the same effect may be accomplished when using only three microphones. The first two microphones would be used in the normal fashion, be that coincident pair, spaced omni, etc., and the third, or solo microphone, would be feed to both the third and fourth inputs with a XLR type “Y” connection. The relative gains of the third and fourth channels are then adjusted to place the solo microphone at the desired position in the sound stage. If phantom power is to be used with the third microphone, both the third and fourth channels phantom switches should be turned on.

5.1.4 Setting Levels

The MPS-400 and MPS-420 do not include metering. It is assumed that the recorders being feed will have the metering necessary to correctly set the systems to their proper operating levels. The output clip point of the microphone preamplifiers is typically as high or higher than the input of the device receiving the signal in which case the metering is not necessary, and indeed is an expensive redundancy.

With any recording, the maximum dynamic range of the recorder should be utilized. Digital recorders, in spite of their dynamic range improvements, should be used as close to digital clip as possible to ensure the greatest bit utilization for the greatest possible accuracy. This presents a conflict between maximum utilization of the media and adequate overload margin to account for the dynamics of the recorded material. It is imperative to do a “run through” for level setting with the orchestra or group being recorded to ensure that the levels have been set accurately for the maximum SPL of the material being recorded. Once this has been accomplished, an extra 5 dB, or so, may be included to account for the psychological difference between a rehearsal and the live performance, particularly with non-professional musicians.

5.2 Discussion of Noise and Microphone Performance

Benchmark has expended considerable effort to produce an amplifier with a 1 dB noise figure so the user may enjoy the highest signal-to-noise ratio possible. It is appropriate, therefore, that a discussion of noise and microphone performance be included.

5.2.1 Noise Primer

Noise figure is a measure of how well an amplifier amplifies the intended signal without adding noise. In the case of the MPS-400 and MPS-420, each amplifier adds only 1 dB of noise to that of the original signal for amplification factors greater than 40 dB. The noise figure is referenced to the Johnson noise of the resistive portion of a transducer source impedance.

Johnson noise may be calculated from:

$$e_n = \sqrt{4kTRB} \quad [1.0]$$

Where:

k = Boltzman's Constant = 1.38×10^{-23}

T = temperature of resistance in degrees Kelvin
(room temperature \approx 300 Kelvin)

R = resistance = microphone source impedance

B = bandwidth = 19,980 Hz

From the above formula we see that the noise of a 150 Ω resistor at room temperature is 222.9 nano volts or -130.82 dBu, whereas, a 200 Ω resistor has a 20 kHz bandwidth noise voltage of -129.57 dBu.

$$\text{dBu} = 20 \log \frac{V}{0.7746} \quad [2.0]$$

Any amplifier, while amplifying the desired signal from a microphone will also amplify the Johnson noise from the source resistance. Therefore, the output noise of a *totally noiseless amplifier* operating at 50 dB of amplification from a source resistance of 150 Ω at room temperature would be -80.82 dBu. The MPS-400 and MPS-420 preamplifier's performance under these conditions is approximately -80.0 dBu. At their minimum amplification (18 dB), each MPS-400, MPS-420 preamplifier has an output noise floor of -94 dBu. The noise increases slowly as the amplification is increased to 40 dB where the output noise is approximately -88 dBu. From this point on the noise will increase directly with the increase in amplification.

Given the source resistance, self noise in the case of a condenser microphone and sensitivity, an evaluation of the performance of any microphone with the MPS-400 or MPS-420 preamplifier systems under various sound pressure level conditions can be accomplished. The following examples utilize two different microphones to apply the understanding of noise.

5.2.2 Electro-Voice RE-20 Microphone

The sensitivity of an Electro-Voice RE-20 is 1.09 mv (-57 dBu) at 94 dB SPL input. If a voltage amplification of 58 dB is used, the output noise of the MPS-400 or MPS-420 preamplifier will be approximately -72 dBu (-130 +58). If the sound pressure level is sufficient to give an output

of +4 dBu then the average signal-to-noise ratio will be 76 dB (72+4). The peak signal-to-noise ratio capability is 99 dBu (72+27). The sound pressure level necessary to achieve an average output of +4 dBu is +97 dB SPL. The peak SPL that the system can handle is +120 dB SPL. At this amplification and SPL the preamp will reach its output clip point of +27 dBu.

5.2.3 Sennheiser MKH-40-P48

The performance of the MPS-400 and MPS-420 with the Sennheiser MKH-40-P48 will now be examined. This microphone has a very high sensitivity of 25 mv/Pascal (10 dynes/cm sq. = 1 Pascal = 94 dB SPL), and very low self noise (a condenser microphone with internal electronics) of 12 dBa. The self noise, therefore, is 1.99 microvolts. This translates to -111.82 dBu.

Using 18 dB of amplification at the MPS-400 or MPS-420 preamplifier, the combination output noise is approximately -93 dBu (20 kHz noise bandwidth). At the reference SPL of 94 dB the output of the microphone is 25 mv or -29.82 dBu. Add 18 dB of amplification and the output amplitude from the preamp is now -11.82 dBu @ 94 dB SPL. Therefore, to get +27 dBu out, the input SPL must be: +27 dBu - (-11.82 dBu) = 38.82 dB + 94 dB SPL to be added to the reference SPL with the resulting 132.82 dB SPL.

Thus there is an average signal-to-noise ratio of 97 dB [+4 - (-93)] and a peak signal-to-noise ratio of 120 dB [+27 - (-93)] at a peak acoustic input of 132.82 dB SPL. This is just below the 135 dB SPL/0.5% THD point of the microphone. 109.82 dB SPL average is required at this amplification for an output of +4 dBu.

Problem

If a digital recorder has a dynamic range (peak signal-to-noise ratio) of 95 dB, an input clip point of +21 dBu into an unbalanced input, and it is desired that the recorder be fed unbalanced with the MPS-400, MPS-420 preamplifier adjacent to the recorder, what is the *lowest peak* sound pressure level that the Sennheiser MKH-40-P48 microphone can receive and still maintain the full dynamic range of the recorder? Also what is the amplification necessary from the MPS-400 or MPS-420 to achieve this performance?

Solution

Since the output of the MPS-400 or MPS-420 will be used unbalanced, the output clip point of the system (one output lead and ground) is +21 dBu. This matches with the recorder's input clip point of +21 dBu.

By using the MPS-400 or MPS-420 as an unbalanced output device 6 dB of amplification is lost, therefore, in this application the preamplifier has an overall amplification range of -8 to +64 dB. Since the dynamic range of the recorder is 95 dB then the recorder noise floor is +21 dBu - 95 dB = -74 dBu. If the microphone self noise is -111.82 then the maximum amplification that can be used is (recorder noise floor - self noise) -74 - (-111.82) = 37.82 dB.

If both the recorder and the MPS-400 or MPS-420 have the same noise voltages, they will add resulting in a 3 dB loss in dynamic range. It is well to keep the MP-4's output noise voltage 3 dB lower than the noise voltage of the recorder. If a maximum amplification factor of 35 dB is

selected, the peak input clip is $+21 \text{ dBu} - 35 \text{ dB} = -14 \text{ dBu}$. From the microphone sensitivity figure given by the manufacturer, at 94 dB SPL into the mic the output voltage is $25 \text{ mv} = -29.82 \text{ dBu}$.

The result is an 15.82 dB increase allowable in SPL from reference; Preamp input clip - sensitivity = additional SPL over reference $\{-14 - (-29.82) = 15.82\}$. That is, $94 + 15.82 = 109.82 \text{ dB SPL}$ clip point. Also, if the maximum SPL that the system can receive is 109.82 dB , then the noise floor of the system is equivalent to $109.82 - 95 = 14.82 \text{ dB SPL}$. In other words the ambient noise floor of the recording environment must be below 14.82 dB SPL to utilize the dynamic range of the recorder, *very* stringent requirements indeed!

If it is assumed that this hypothetical recorder is a "semi-pro" device and that a nominal input level of -10 dBV is what will give a 0 indication on the device's meter ($-10 \text{ dBV} = -7.78 \text{ dBu}$), then the average SPL (assuming an average type meter) at the microphone is $109.82 \text{ dB SPL} - 28.78 \text{ dB} = 81.04 \text{ dB SPL}$.

While the above calculations are hypothetical, they are close to the real world. They demonstrate how the microphone and preamp can set the dynamic range of a system. They also highlight the need, in this digital recording era, to use recording environments with extremely low acoustic noise levels to realize the recorder's full dynamic range. In most cases air handling equipment will need to be turned off during the actual recording, and even this may not be enough improvement if the site is near a transportation terminal.

The amplification required for most microphones will typically be between 20 and 40 dB and the preamp section will most often be the limiting factor in the output noise of a console or other electronics prior to any recording or transmission medium. The majority of amplification needed, consistent with desired headroom, should be taken from the MPS-400 or MPS-420 preamplifier since it has the lowest noise figure of any of the amplifying stages.

5.2.4 Miscellaneous

The amplifier, as noted above, may be used for boosting marginal line amplitude signals with minimum output noise. For example, when operated at 30 dB of amplification, the noise output of the preamplifier is still 92 dBu (150Ω source).

Since the output impedance of the card is 60Ω , the length of the line that may be driven is three to four times longer than can be driven with a 150 to 200Ω microphone drive impedance for the same small signal high frequency cutoff point. For example, almost 2800 ft. of foil shielded cable may be driven with a small high frequency cutoff of 30 kHz . Since the output device has a current limit of 40 mA. , cable capacitance will be the limiting factor in the actual slew rate at the receive end of the cable being driven by the MPS-400 or MPS-420. For this reason the use of very low capacitance cable such as Mogami 2574 is recommended for long runs. It has a capacitance of 6 to 7 pF/ft. between conductors, versus 30 to 32 pF/ft. to be found in most foil shielded cables. This cable is available from stock at Benchmark.

5.3 MPS-400 and MPS-420 Preamplifier Operation

The following is a complete description of the circuitry comprising the MPS-400 and MPS-420 preamplifiers.

5.3.1 General

The superior performance of the MPS-400 and MPS-420 is the result of careful attention to each element of the circuit design. For example, in the area of common mode rejection the MP-4 preamp has additional performance designed into its circuitry, over what is normally found in microphone preamplifiers.

With the addition of a common mode filter all interfering signals see a 26 kHz LC low pass filter and are down 60 dB at 1 MHz while the desired differential signal is unaffected. The performance of the preamplifier section is much superior to preamps found in audio consoles, with THD at A = 50 dB, 20 Hz to 20 kHz = 0.002% (noise limited) and CCIF IMD of 0.003% out to 60 kHz at 0 dBu out, the real key to outstanding aural performance.

5.3.3 Differential Converter

The headroom of the input stage has been reduced by the bias configuration 6 dB from what would normally be available to a stage with a 30 VDC supply. Therefore, the differential input converter has +6 dB of amplification to equalize the clip points. The output stage has additional amplification of 6 dB from the inverting follower yielding an amplification range of +18 to +70 dB for the electronics. The 20 dB pad gives an overall range of -2 to +70 dB.

The differential converter also converts the differential signal from the first stage to a single-ended signal and is one half of the differential output stage. This stage rejects any power supply noise and any low frequency common mode signals that may be present at low amplification.

The common mode rejection is adjusted by using a single-ended input source (on both input lines) whose amplitude is -20 dBu and an amplification of 40 dB on the MPS-400 or MPS-420. Both the resistive trim and capacitive trim are made with an input frequency of 2 kHz. Typically the null that can be achieved is -100 dB (-80 dBu).

5.3.2 Input Stage

The input signal first encounters the phantom power circuit which consists of a pair of 6.81K Ω resistors that feed power to the microphone line. This phantom power is turned on and off utilizing the +48 V red pushbutton switch located on the MPS-400 or MPS-420 front panel.

Next is the 20 dB pad which consists of two 750 Ω resistors plus one 150 Ω resistor. The 20 dB pad is activated by the -20 dB gray pushbutton switch located on the MPS-400 or MPS-420 front panel.

Next in line are input coupling capacitors. These capacitors are a very low leakage variety of aluminum electrolytic rather than tantalum. They are noted for their superior dielectric absorption characteristic (distortion producing mechanism in capacitors). Additionally, all aluminum electrolytics are bypassed with film capacitors. Low leakage capacitors are used to ensure low noise since any leakage currents in these capacitors results directly in input noise to the amplifier.

The next section is the common mode choke. This consists of a highly symmetrical dual winding on a common toroid core with an inductance on each winding of 38 millihenries. The operation of the choke is such that with a differential signal the magnetic fields created by the two highly symmetrical, but opposite windings, will cancel one another. This results in a net inductance of zero. However, with a common mode signal the inductance remains. Coupled with the 1000 pF capacitors and 10 K Ω termination resistors it forms a two pole Butterworth low pass filter with a 12 dB/octave roll off.

In addition there are four zener diodes, two on each input. The voltages of these zener diodes are chosen such that the sum of the forward drop and the zener voltage is less than the zener turn-on voltage of the transistors. This protects the ultra low noise transistors. It prevents them from going into the emitter-base zener mode which would destroy their low noise capability and make the devices more prone to failure. The zener diodes also prevent damage to the input from phantom power turn on transients.

Next is the low noise active differential amplifier. This topology is an emitter feedback differential amplifier using ultra low noise transistors. The noise figure of the transistors is less than 1 dB referenced to 150 Ω and is still less than 2.5 dB referenced to 10 Ω . These transistors were developed for use as moving coil head preamplifiers and their noise performance is maintained by virtue of the fact that no series input resistors are used prior to the devices. By coupling the input signal to the bases of the transistors the only noise producer in the signal path is the intrinsic base resistance of the transistors. This has been reduced to a very low amount by their design (approximately 2 Ω).

Since the common mode filter has no appreciable series resistance it also does not limit the noise performance of the transistors. The source resistance of the transducer becomes the major noise producer. The amplification of this stage is established by the variable resistor between the emitters of the two transistors and the feedback resistors from the outputs of the op-amps. The values selected allow for an amplification range of 6 to 58 dB at the differential pair. The bias currents for the stage are set by the fixed voltage bias point of the op-amps and the resistor networks.

5.3.4 Output Stage

The output stage consists of both the differential converter and a unity gain inverting follower circuit to produce the balanced output required.

The DC offset voltage from the output amplifiers of the MPS-400 and MPS-420 is typically less than 2 millivolts. The output capacitors may be bypassed if a small offset voltage can be tolerated. The output capacitors indeed should be by-passed if the MP-4 card will be working into a 600 Ω load, not at all recommended, to maintain the desired low frequency cutoff. If the amplifiers will never be used with condenser microphones where phantom power is needed then the phantom voltage isolating caps may be bypassed. Additionally the phantom power resistors may be removed to raise the input impedance to approximately 20 K Ω . The capacitors that couple the first active stage to the differential converter, however, may never be bypassed as they always have a DC voltage across them of approximately 7.5 volts.

5.3.5 Measurement Curves

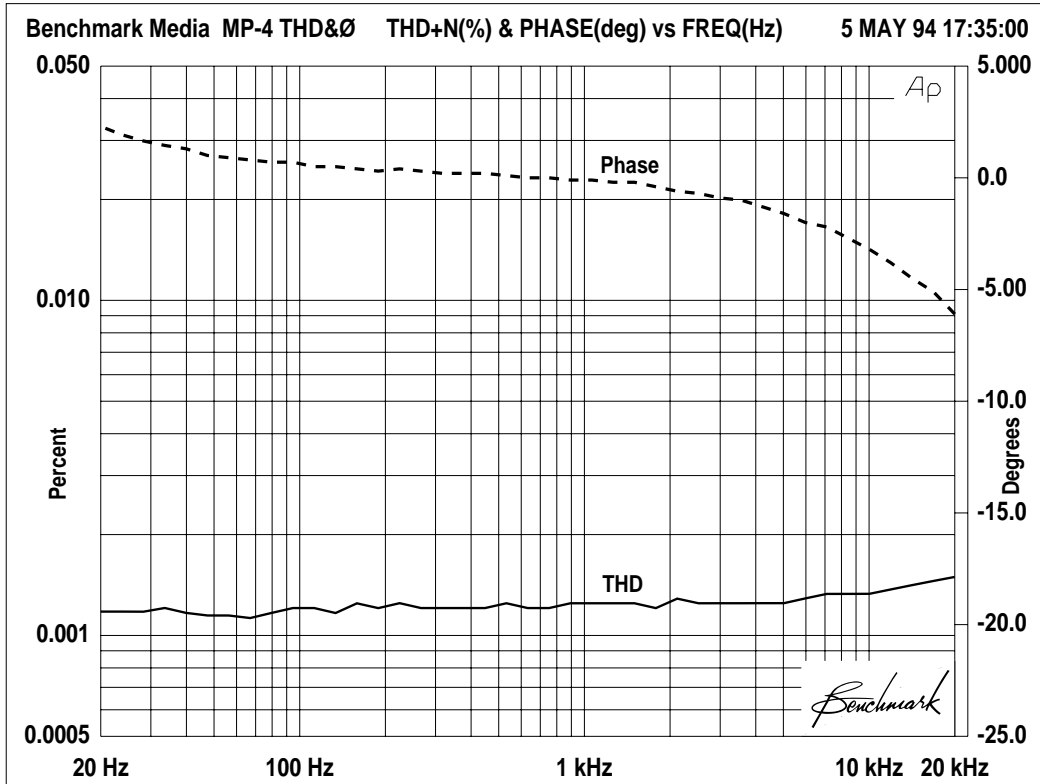

Figure 8 - MP-4 THD Sweep - 20 Hz to 20 kHz

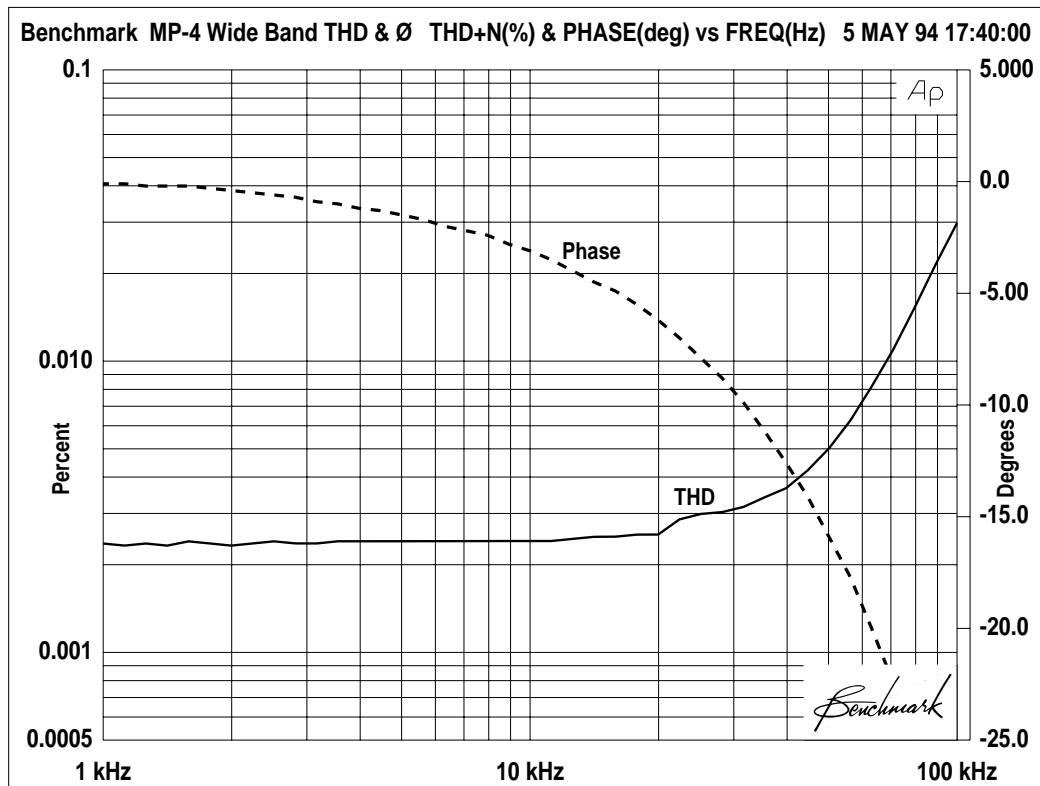

Figure 9 - MP-4 THD Sweep - 1 kHz to 200 kHz (Wideband Noise Filter In Place)

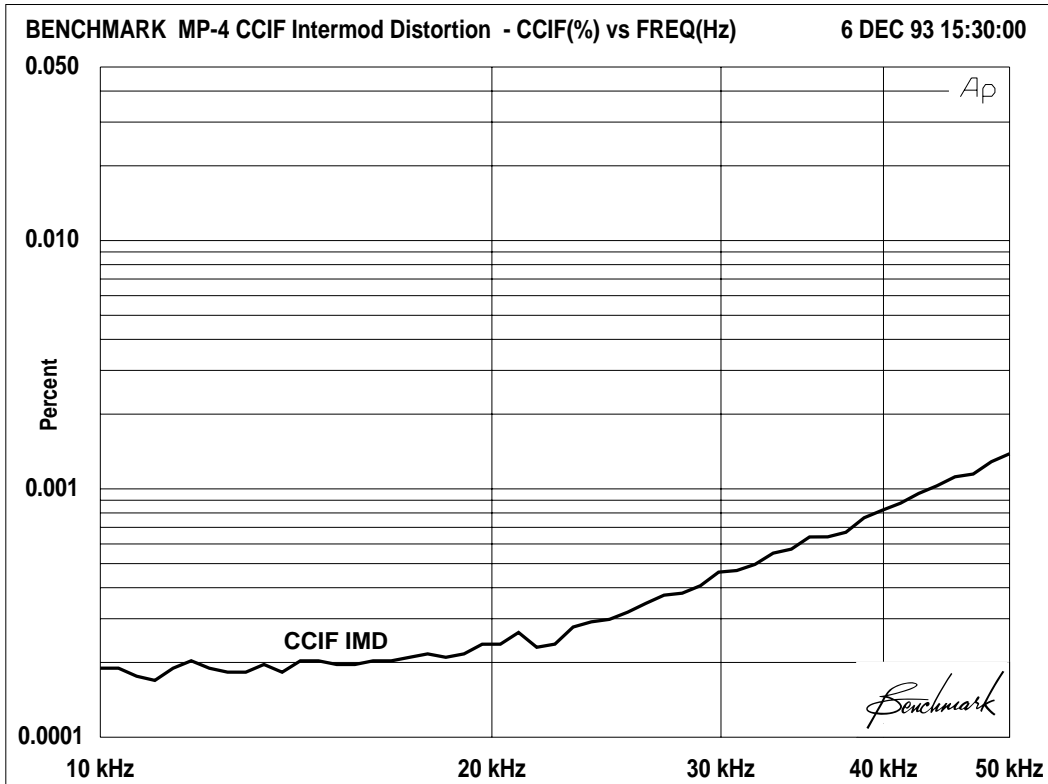

Figure 10 - MP-4 CCIF IMD - 1 kHz Difference Frequency, 10 kHz to 50 kHz

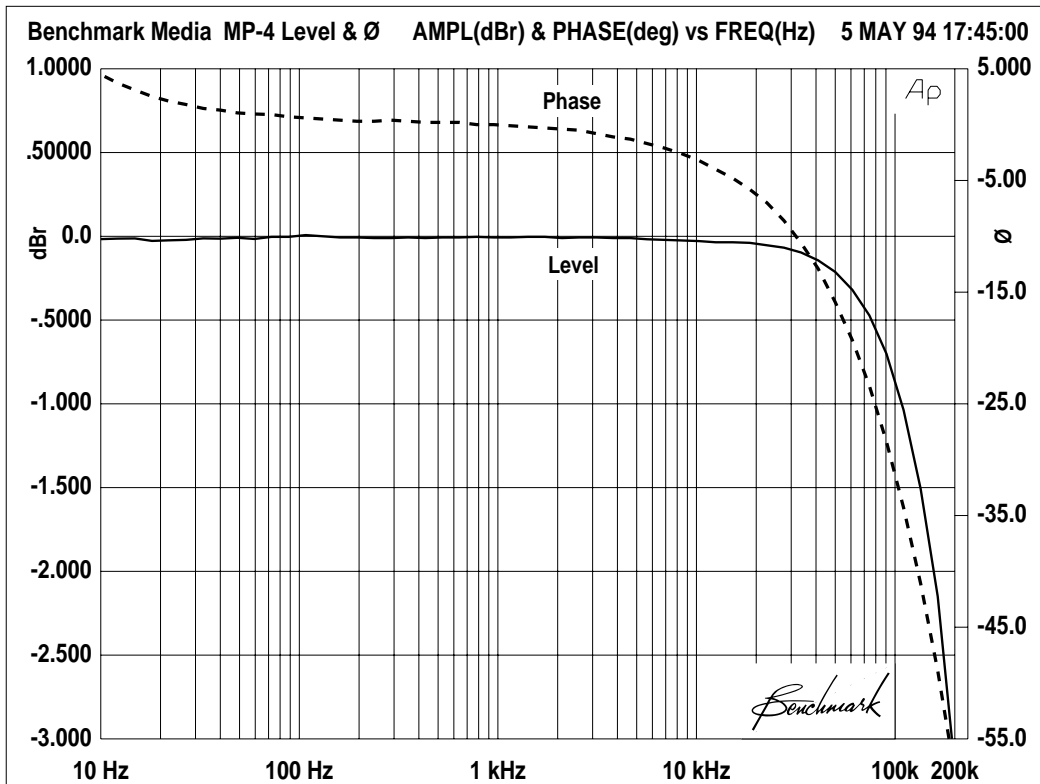

Figure 11 - Frequency Response, 10 Hz to 200 kHz

Figures 8, 9, 10 and 11 show measurement curves for the MPS-400 and MPS-420 preamplifiers. The measurement curves were made with power supply voltages of ± 18 VDC (A = 40 dB) with an input amplitude of -20 dBu and an output amplitude of +20 dBu.

5.4 MPS-420 Additional Features

In addition to the four microphone preamplifiers described above, the MPS-420 also includes two DOM-3 Differential Output Mixer units and an HPA-1 Stereo Headphone Amplifier. Their operation is described as follows.

5.4.1 DOM-3 Operation

As provided in the MPS-420, the DOM-3 mixer units allow channels 1 and 3 to be summed to the left (SUM-A) output and channels 2 and 4 to be summed to the right (SUM-B) output. The DOM-3 is a balanced output device that has variable gain from full OFF to +12 dB, two 10 K Ω inputs, an output impedance of 60 Ω . The circuitry is on two small printed circuit boards (0.65" wide by 1.65" long) and mounted within the MPS-420. The outputs are wired to XLR type connectors on the rear panel of the MPS-420.

The operational amplifier used is a NE5532 for outstanding aural performance. The mixed output level is 3 dB lower than the direct outputs. This provides the correct output level when two un-correlated signals are mixed at the DOM-3. The output load will be 3 dB higher than the direct outputs for fully correlated material.

The DOM-3 is powered from the ± 18 VDC power supplies that power the MPS-420.

The output impedance of the DOM-3 is 60 Ω balanced and 30 Ω unbalanced. This is achieved with 1% metal film build-out resistors. A 60 Ω output impedance has been found to be the optimum drive impedance for today's foil shielded cables. This allows the longest possible cable runs to be made without excessive high frequency roll-off and without significant high frequency response peaking.

Another benefit of the 60 Ω output impedance is that there is only 0.8 dB amplitude difference between a bridging input and a 600 Ω load input. See "A Clean Audio Installation Guide" by Allen H. Burdick, A Benchmark Media Systems application note included within this manual.

5.4.1.1 DOM-3 Balanced or Single Ended Outputs

The DOM-3 Differential Output Mixer can be used as a balanced or single ended output. When using the DOM-3 as a balanced output device both of the outputs (inverting and noninverting) will be utilized. When using the DOM-3 as a single ended output use *only one* of the two outputs (either the inverting or the noninverting). Under no circumstances should one of the outputs be tied to ground as would be done with a transformer output. The active balanced output is already ground referenced unlike the transformer type outputs. See figure 5 for the correct output wiring to a single ended input.

!!! Warning !!!

Tying one of the outputs to ground will cause a large amount of distortion to occur as well as overheating of the op-amp. See Figure 5 for a correct wiring diagram.

5.4.1.2 DOM-3 Terminations and Output Amplitude

The impedance matched audio interconnect system developed in the days of tube amplifiers is now outdated for anything but extremely long cable runs. With modern operational amplifier technology it is no longer necessary (nor even desirable) to terminate audio lines with a “matched” low impedance unless the length of the cable approaches 1/4 wavelength at the highest frequency of interest (2.33 miles at 20 kHz).

Today the voltage sourced interconnect system is becoming universally used. The voltage sourced system features a low source impedance of approximately 50 to 60 Ω and a high input impedance of 10K Ω or higher. The advantages include:

- Less power drawn from the source equipment resulting in less heat generated.
- Lower distortion generated by the output stage doing the driving.
- 14 dB lower noise pickup by the interconnected lines due to the lower source impedance.

The DOM-3 was designed with this in mind and while it will drive a 600 Ω load it does so with reduced headroom (lower clip amplitude) due to the internal current limiting of the op-amp used. For the best headroom in the system, DO NOT put a 600 Ω resistor at the receiving end of the cable being driven by the DOM-3.

The maximum output from the DOM-3 operating as an unbalanced output is always 6 dB lower than when operating as a balanced output.

5.4.2 HPA-1 Operation

The HPA-1 Stereo Headphone Amplifier is an integral part of the MPS-420 system and is used to monitor the summed channels of the DOM-3 Differential Output Mixer. The left side of the HPA-1 monitors the DOM-3 “SUM-A” output and the right side of the HPA-1 monitors the DOM-3 “SUM-B” output.

The HPA-1 features a current boosted TLO72 with a 60 kHz bandwidth at full gain, a gain range of off to +18 dB and a noise floor of -90 dBu at full gain. The HPA-1 is ideal for the “Studio Series” headphones in the 200 to 600 Ω range.

The HPA-1 power supply inputs are internally wired to the ± 15 VDC system power supply.

Any stereo headphone with an actual impedance of 200 to 600 Ω can be used with the HPA-1 as installed in the MPS-420. High impedance headphones such as the 600 Ω AKG 240 series are recommended for highest performance. Figures 12 and 13 Amplitude, THD, and Phase vs. Frequency data at Unity gain and Full gain, both wide band and over the 20 Hz to 20 kHz audio bandwidth.

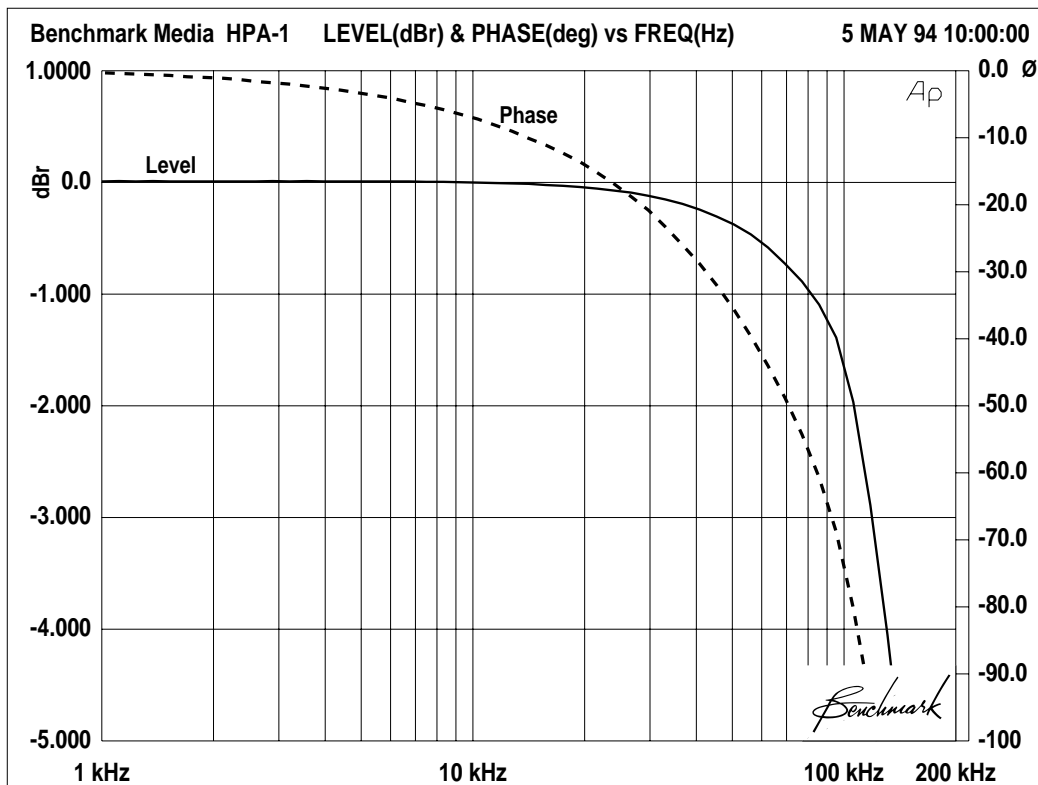

Figure 12 - Amplitude & Phase vs. Frequency. Unity Gain - 0 dB, 200 Ω load

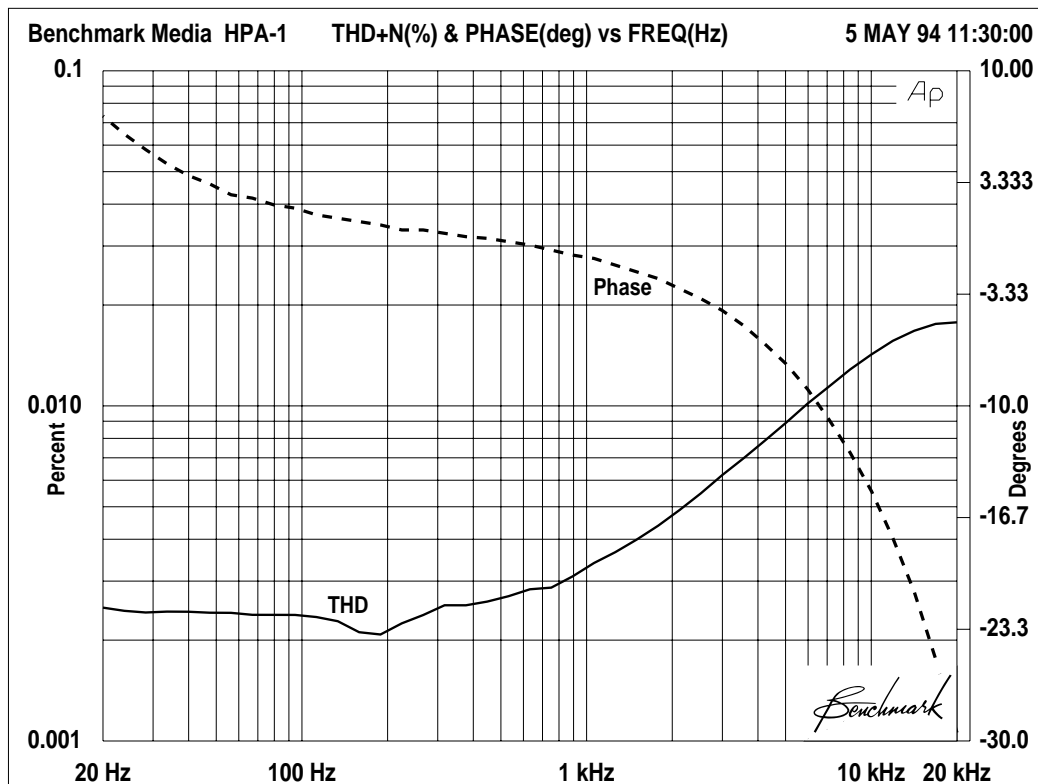

Figure 13 - THD & Phase vs. Frequency. Full Gain - 16 dB, 200 Ω load

Gain at the headphones is affected by the load impedance of the headphones. This is due to the 30 Ω buildout resistors that are used to protect the current boost amplifiers. At the amplifier output itself the gain is constant but at the headphones a voltage divider has been established. With a headphone impedance of 600 Ω the gain at the headphones is 18 dB. However, with a headphone impedance of 200 Ω the gain at the headphones is 16.5 dB.

The HPA-1 consists of a dual operational amplifier with current boosted outputs. The output current boost stages consist of two high speed buffer amplifiers that are in the feedback loop with the op-amp. These devices have a 300 mA output current capability and are ostensibly current limit protected. It is our experience that these devices can be overloaded and experience failure with shorted outputs.

Low impedance headphones are not to be used. While the HPA-1 technically could supply the required current demanded by low impedance headphones, the PS-10B does not have enough current capability for headphones under 60 Ω impedance.

!!! Warning !!!

Use headphones with an impedance of 60 Ω or higher only.

The gain of the amplifiers is controlled by a dual 100 K Ω linear taper potentiometer that is in the feedback loop of the composite amplifier. The advantage of this configuration is that the noise floor is always optimum for any given amplification factor. In this configuration the gain range is from full OFF to +20 dB. The gain control is located on the MPS-420 front panel.

6.0 Servicing

The choice of quality components and care in design and manufacture of the MPS-400 and MPS-420 Systems should help provide a long and trouble free life under normal conditions. If the MPS-400 or MPS-420 should require servicing, Benchmark recommends that it be accomplished at the factory level. If repairs are to be accomplished in the field Benchmark offers the following tips.

6.1 Soldering Technique

Once the faulty component is isolated extreme caution must be exercised when removing the component and soldering in a replacement. Benchmark strongly recommends the use of a de-soldering station such as the Hakko 470.

The proper technique is to apply the de-soldering iron tip to the area to be de-soldered and wait for the solder to liquefy while observing the top side of the circuit board. As the solder becomes liquid the vacuum is applied while moving the tip of the iron and rotating the lead of the component coming through the circuit board. Rotating the lead without applying pressure to the pad will allow removal of solder in the plated through hole. If this procedure is correctly applied the component will often drop off of the circuit board.

If the solder is not thoroughly removed from the plated through hole when attempting component removal the plating will be removed from the hole. If the solder removal was not

thorough the first time do not attempt to re-heat the area with the de-soldering tool. Doing so will often overheat the pad and not heat the area that is in need. The circuit board could be damaged as a result.

Re-solder the joint and re-apply the proper technique by allowing the solder in the joint to thoroughly liquefy before applying vacuum.

The following is a soldering technique that was developed by NASA to ensure highly reliable solder joints. The component lead is heated first since it usually has the larger mass and has little chance of being damaged by excess heat. This is done by applying a small amount of solder to the tip of the soldering iron while simultaneously applying the iron to the component lead. This allows some flux to make it to the component lead. The iron should be slightly above the circuit board. When the lead reaches temperature it liquefies the solder adjacent to it and has good wetting. Slide the soldering iron down the lead and heat the printed circuit board pad while applying a controlled amount of solder to the joint. All of this should take no longer than a couple of seconds.

The component to be mounted on the circuit board may have leads that are oxidized. Clean them with a "Scotch Bright" abrasive pad, a fine bristle fiberglass brush or equivalent method.

6.2 HPA-1 Troubleshooting

Generally almost all failures that occur with any power amplifier are loss of one or more current boost stages. This is often the result of an inadvertent short to the output under high signal conditions. This usually only happens if the user bypasses the 30 Ω output resistors.

If the PS-10B is supplying power to the MPS-400 or MPS-420 it will sag under this condition, however, the power dissipated and the heat generated in the offending current boost stage will usually identify it. The op-amp driver may be very warm under these conditions but will seldom be the problem.

This completes the MPS-400 / MPS-420 manual.

050594

Lexan® is a registered trademark of the General Electric Co.

BENCHMARK MEDIA SYSTEMS, INC.

5925 Court Street Rd. Syracuse, NY 13206
315-437-6300, FAX 315-437-8119