

OSC-01 Instruction Manual

1.0 General Features

The OSC-01 daughter board allows the easy insertion of a test tone to the audio chain. The on-board, fixed frequency oscillator is of high purity. This allows it to be used as a reference for THD spot measurements as well as a reference for amplitude. A fine frequency trim allows that adjustment to be made so even frequency can be used as a reference, i.e. 440 Hz in the tuning of instruments.

In addition to the on-board oscillator, the OSC-01 has an auxiliary input for the insertion of a test signal such as those from an Audio Precision System One, a Sound Technology, Amber or other automatic test system. The third input is a highly trimmed differential input for a hum free interconnect.

All four of the aux lines are used with the OSC-01. Aux line "a and b" are used for the balanced third input. Aux line "c" is used as the toggle command to select between the normal inputs to the System 1000 module and the test signal, be it the on-board oscillator or the external input, that has been chosen. Aux line "d" is an unbalanced output from the on-board oscillator. Jumpers allow the on-board oscillator to operate; 1. at all times, 2. only when selected by the external toggle command, 3. not at all. See section 3.5 for specific applications and the necessary jumper configurations.

2.0 Unpacking and Physical Installation - General Overview

As with any delicate electronic equipment, care must be exercised in the handling of this board. The OSC-01 daughter board uses as a part of its switching circuitry CMOS logic devices. These devices, while internally diode protected, may be damaged by electrostatic discharge. Appropriate caution must be taken in their handling, particularly in low humidity environments.

Carefully unpack the RGC-01 and place it on the work bench for installation on its intended System 1000 module.

2.1 Physical Installation

Remove from operation the System 1000 module intended to receive the OSC-01.

Some early System 1000 distribution amplifiers were shipped without the eighteen header pins installed. If your System 1000 has module pins installed, skip to section 2.2. If your board does not have the header pins you have two options available to you. First, and usually most preferable from a down time perspective, you may install the pins yourself. We will supply the pins. Secondly, you may return the board to the factory and the pins will be installed for you at no charge.

2.1.1 Installation of Header Pins

1. Read the instructions on de-soldering and re-soldering in your System 1000 manual.
2. Remove the shield plate from the back of the System 1000 card.

3. Insert the 10 and 8 pin strips into their mating housings on the daughter board. You will use the daughter board as a jig to facilitate pin alignment.

4. Use a static controlled work station, with a minimum of a grounded soldering station, grounding wrist strap, and a conductive work mat. Solder the 10 and 8 pin strips into the module. The best procedure for this is to solder only one pin in each of the two strips. Check to be sure that the strips have been seated directly against the module. If some readjustment is necessary, it is very easy to do with only one pin soldered by simply re-heating the joint. When you are satisfied that the pins are seated and in alignment, solder the remainder of the pins.

5. De-flux the board using a solvent appropriate to the flux being used.

6. Check the solder work to be sure that no solder bridges or cold solder joints exist. Repair as necessary.

7. Return the shield plate to the card.

2.2 Installation of OSC-01 on Module

The OSC-01 has two sets of female header pins that extend from the bottom of the board. One of these sets has ten pins and the other has eight. When installing the daughter board on the System 1000 module, make sure that the corresponding number of pins is being inserted into these headers, as it is possible to invert the card.

!!! Warning !!!

It is absolutely imperative that the solder joints on the bottom of the daughter board do not short against the tops of aluminum electrolytic capacitors, or wire leads that may be present. To do so will, at minimum, cause improper operation and at worst may cause catastrophic failure of the daughter board.

Due to the extreme density necessary to achieve the unparalleled versatility and flexibility of the System 1000, the decision was made to allow, in some cases the two boards to come into physical contact. If it is necessary, use the enclosed self adhering insulating material to insulate the tops of the aluminum electrolytic capacitors. Or a Lexan™ sheet may be used to totally isolate the bottom of the daughter board from the components of the module.

!!! Warning !!!

The OSC-01 may not be plugged on to a System 1000 module while there is power on the module. To do so will cause damage to the CMOS logic on the daughter board.

While this could only be accomplished with the System 1000 module on the work bench or on an extender, it is a certainty that damage will occur should the engineer forget. The combination System 1000 module and daughter board, however, may indeed be inserted into the System 1000 main frame with power on. When plugging the combination into a powered frame, insert the card into its connector quickly and firmly to eliminate possible time difference in contact mating.

3.0 Electrical Installation - General Overview

In this and other documents we will be using the term dBu. 0 dBu is defined as 0.7746 volts. This is the same voltage that would be found on an audio transmission line operating at 0 dBm when properly sourced and terminated with 600 ohms. The use of this voltage as a reference is desirable when using the readily accepted volume indicator commonly called a VU meter. The "VU meter" is of course a voltage measuring device, where 0.7746 volts will give a "0" indication when fed with a steady tone. Hence it is desirable to maintain the same input voltages with our voltage sourced system as would be found within the power matched system. See "A Clean Audio Installation Guide" by Allen H. Burdick, a Benchmark Media Systems application note.

While the dBu is not a widely recognized standard it is found in the NORDIC standards (N-10) and is in very common usage, particularly in Europe. This causes us to accept it as the most logical way to define the voltage reference that relates to the antiquated power matched system. Occasionally, in some of our older documentation, the term dBv will be seen. This has the same meaning as dBu. Others will use dB/7 or dB/0.775 to indicate the same voltage reference.

3.0.1 Oscillator THD

The low Total Harmonic Distortion of the oscillator was the primary design goal of the OSC-01, with amplitude stability virtually as important. As such the design of the oscillator was chosen to be of the "State Variable Filter" variety with a temperature compensated active AGC to control the amplitude of the oscillator. The oscillator has two outputs. One is through a variable gain section, the second is a direct output. The THD of the direct output is that of the oscillator and as such is the purest available from the card. Its THD is in the neighborhood of 0.0008%. This is available on aux line "d" as an unbalanced output with an amplitude of approximately +12 dBu. If you desire to use this signal, it may be fed to another distribution amplifier, for full time distribution throughout the plant, or to a DOA-1 for a single line, balanced output.

The THD of the System 1000 output will be slightly higher than that of the oscillator. This is a result of the FET switches on the daughter board and the output stage of the System 1000 module.

3.1 Remote Oscillator Select Switch

The output signal from the OSC-01 daughter board can be either the normal incoming audio to the daughter board or the selected test signal. Which you receive as output is determined by the logic voltage applied to aux line "c". This voltage needs to be either "logic ground" or the +12 volt "logic supply", both of which are available at the card edge connector. Logic ground will give the normal incoming audio, while +12 volts will yield the selected test signal.

We suggest that a single pair of foil shielded cable be used for the remote control. There are two ways that pair can be wired. The first is; the wiring of the shield to the logic ground, the +12 volts to the red wire and the switch return to the black wire. You must include a 100 Ω resistor in series with the +12 line at the card frame. This will

prevent any large currents from flowing should the remote line ever become shorted. The input impedance of aux line "c" is high enough for this resistance to be insignificant. The switch must be of the continuous contact type, that is NOT a momentary contact type. It can be either a "Push-Push", or the bat-handle variety. A suggested wiring diagram is shown in figure 3.0.

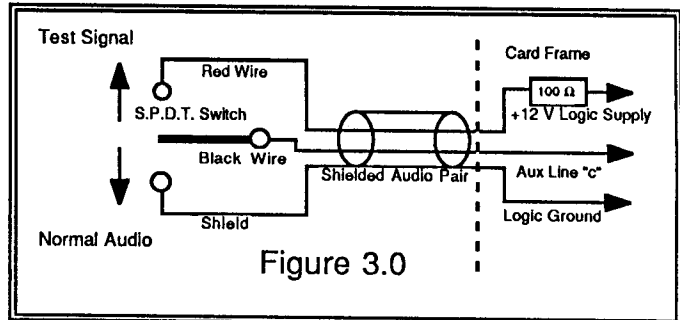

The second way to wire the remote cable is to not tie the logic ground to the shield, but allow the internal pull-down resistor to provide the "logical 0" for the switch input. Either way that you choose to wire the remote cable a 100 Ω resistor should must be included in the +12 supply to the switch.

3.2 External Test System Input

Input from an external test system may be made to the balanced input of the OSC-01 via aux lines "a & c". To select the external test system rather than the on-board oscillator, S1, the small black slide switch on the lower front edge of the daughter board must be moved from the up position to the down position. When in this position the remote toggle will give as output, the aux input rather than the on-board oscillator.

3.3 Physical Wiring Particulars

Two pin Molex SL housings and pins are preferred for the interconnection of the wires to the card edge connector. They may be used for both the logic power-voltage pickoff and the connections to the aux lines. If two pin housings are not available, three pin housings may be used horizontally between pins on opposite sides of the 70 pin connector. That is pin positions "a" and "c" would be handled by the top housing (with the center position empty), and positions "b" and "d" would be used with the bottom housing.

3.4 Operational Setup

!!! Important !!!

The basic signal routing for the System 1000 module has now been moved to the daughter board. If the OSC-01 is to be used on a DA-101, where the balanced output feature is selected, that is switch 3 of DS-1 on the module is turned on, that switch alone should be left on. All other switches in DS-1 should be turned off. With the DA-102, the dip switch assembly on the daughter board totally duplicates, and supersedes that of the module, so all signal routing switches on the module will need to be turned off. Now

switches on the module will need to be turned off. Now referring to the daughter board, schematic select the appropriate signal routing switches for the System 1000 module in use. I.e. when using the OSC-01 with the DA-101 only switch sections 1 and 3 would be used, and which of those two would depend on whether input one, input two or both were being used. With the DA-102 switch sections 1 and 3 will feed the left and right inputs, respectively, to the left output. Sections 2 and 4 feed the inputs to the right output.

It is **important** to set up the signal routing dip switch prior to setting the oscillator amplitude. If you are using the System 1000 module as a summing amplifier, that is you are mixing two signals to one, then there will be a similar (6 dB) addition with the test signal used and the amplitude of the oscillator will have to be adjusted accordingly.

The basic parameters of the oscillator and input section have been adjusted at the factory. You may find a need to adjust the amplitude potentiometer, R2108, to match your particular temperature environment once the card has reached its thermal equilibrium. R2108 is physically next to the small black slide switch on the front edge of the card.

3.5 Jumper Setup

A single jumper near the center of the board configures the operation of the on-board oscillator. With the jumper in the "A-B" position (left two of the three pins) the oscillator will turn on when the test signal is selected via the external toggle. With the jumper in the "B-C" position (right two of the three pins) the oscillator will remain off no matter what the external toggle position. If the jumper is "stored" to the side on just one pin of the three, the oscillator will remain on at all times even though it is not being fed to the module. Each of these three functions have their place.

For most applications the oscillator may be left on at all times. The crosstalk into the output from the oscillator is at approximately -80 to -90 dBu. This is usually low enough to be of little concern. If however this is of concern then the "A-B" jumper position should be chosen. Turning the oscillator on at the beginning of use involves settling time. The settling time is approximately 2 to 3 seconds, during which the amplitude will overshoot the reference level by at least 6 dB. This may or may not be a disadvantage, depending upon your system requirements. When using the external test system input to the OSC-01, it may be preferable to turn the oscillator off entirely, in which case the "B-C" jumper position would be chosen.

4.0 Theory of operation

Referring to the schematic and the parts placement diagram for the OSC-01, you will notice that we are using a grid system in the parts numbering scheme, and the resultant part numbers allow easy location on the printed circuit boards and parts placement diagrams. As a result the part numbers do not follow the conventional sequential incrementing.

4.1 Oscillator

The OSC-01 uses the "State Variable Filter" typology oscillator circuitry. The state variable filter normally consists of two integrators, an inverter circuit and feedback

loops, of which there are many variations. This filter typology is now modified by the addition of enough positive feedback to cause oscillation and an active AGC for level control. There are three distinct feedback loops in the oscillator. One, a positive feedback loop that helps set the basic filter parameters, consists of a 10 K Ω resistor from the output of U111 pin 7 to pin 2 of U112. The second, the positive feedback loop that brings the circuit into oscillation, consists of the 82.5 K Ω resistor and the 20 K Ω potentiometer that tie from pin 7 of U112 to pin 2 of U112. Additionally an ultra low resistance N channel FET, Q211, has been added to the positive feedback loop in order to turn off the oscillator if desired. The third feedback loop is the AGC circuit. The AGC circuit is a negative feedback loop. The loop consists of a 10 K Ω resistor from pin 7 of U112 and goes to pin 3 of U112, the 475 Ω resistor and the FET Q113. Local feedback in the form of the two 100 K Ω resistors around the FET minimize the the second harmonic distortion generated by this device.

The AGC controller circuit consists of: the three diodes CR113, 114 & 115, that combine samples of the three outputs into an "analog or" circuit, the components in the string from pin 2 of U111 to the negative voltage reference U113 and the feedback components between pins 1 and 2 of U111. The AGC controller amplifier is an open loop device and depends on the continuous return of control information (amplitude) to avoid saturating. Since the amplifier is acting as an integrator and there is no DC feedback current, the amplitude of the oscillator can be precisely controlled by the currents that go into and out of the summing node, pin 2 of U111. In that regard R1102 is the basic oscillator level set potentiometer. It is normally operating at its full amplitude of +12 dBu. Potentiometer R2105 in the positive feedback loop is normally turned to minimum for the best settling time. Potentiometer R1112 is the fine frequency trim and may be readjusted from the factory setting once the card reaches thermal equilibrium.

4.2 Oscillator Output and Amplitude Adjust

The output of the oscillator takes two paths. One is a direct path to the outside world via coupling capacitors to aux line "d". The second path is through a variable gain stage to the test signal source select switch, S211. Gain control potentiometer R2108, a front card edge control, has a somewhat limited range, but will cover the common professional system references of 0, +4 and +8 dBu. This is true even for signal routing switch (S121) conditions where there is the +6 dB signal addition.

4.3 External Input

The second input to S211 is the output of the "External Test System Input" differential amplifier, 1/2 U211. This amplifier has been factory trimmed for better than 90 dB CMRR at low frequencies (out to 2KHz) and approximately 75 dB at high frequencies. Under actual operating conditions a degradation of up to 25 dB may be expected depending upon thermal environment. The adjustments for common mode rejection are very sensitive and once set should never need to be readjusted, unless some component in the passive

bridge around the operational amplifier is changed, even changing the op-amp itself should not degrade the CMRR.

4.4 Test Signal Source Select Switch

The output of the selection switch, S211, feeds inputs to two sets of FET switches.

4.5 Normal Audio Input

The second set of inputs to the FET switches is fed from the outputs of the inverting input stages from the module. These input stages are 1/2 of the dual operational amplifiers U122 or U222, the other half is the corresponding output amplifier section. All of the amplifier sections on the daughter board are compensated for a high frequency roll off frequency of 319 KHz. This is accomplished by the choice of the feedback resistor capacitor pair.

4.6 Output Section

Four switches are contained each of the two 4066 packages, U121 and U221. The state of the FET switches is controlled by two simple transistor inverters Q221 and Q222. The FETs are between the input resistors and the summing nodes of the output amplifiers. Their operation is as a current switch. They will either pass the input current to the summing node of the amplifier or to ground depending on which state has been chosen. Again a simple single transistor inverter is used to control the alternate FET in the two FET pair. The output of the two output stages feeds the signal routing selection switch, S121. This switch duplicates and supersedes any signal routing switch on the module. As a result any switch or jumpers on the module that perform the function of signal routing, with the DA-101 exception noted above, must be turned off or removed.

This completes the OSC-01 Instruction Manual

"Lexan"™ is a trademark of the General Electric Co. Inc.

!!! Warning !!!

When using the OSC-01 with a D.A. module as a dedicated oscillator - D.A., you must strap +12 volts from the logic +V buss (second buss from the bottom on the System 1000 frame) to aux line "c" (pin #60 on card edge connector). This "enables" the FET switches which allows the oscillator signal to pass to the D.A. output sections rather than sending the signal from the D.A. inputs to the D.A. outputs. Also the signal routing DIP switch on the module must have every switch turned off and the dip switch on the OSC-01 must have switch sections 1 and 4 turned on.

Benchmark MEDIA SYSTEMS INC.

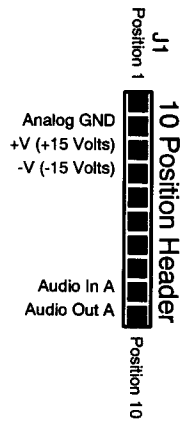

**Add Jumper Between
Pins 12 and 14**

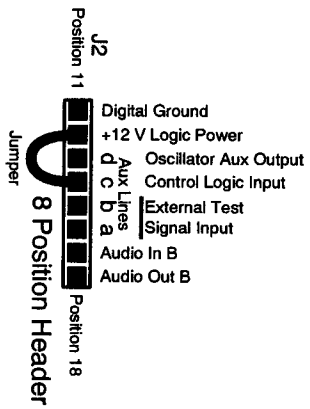

BENCHMARK MEDIA SYSTEMS, INC.

OSC-01 Oscillator Daughterboard Jumper

SCALE	1X	PCB#		DRAWN BY	A. H. Burdick
DATE	10/19/94			ASSEMBLY #	
SIZE	A	COMP. ASS'Y		DRAWING #	

REVISIONS		DATE	APPROVED
ZONE	DESCRIPTION		
A	SEE DCN NO. 238	4/23/92	RD

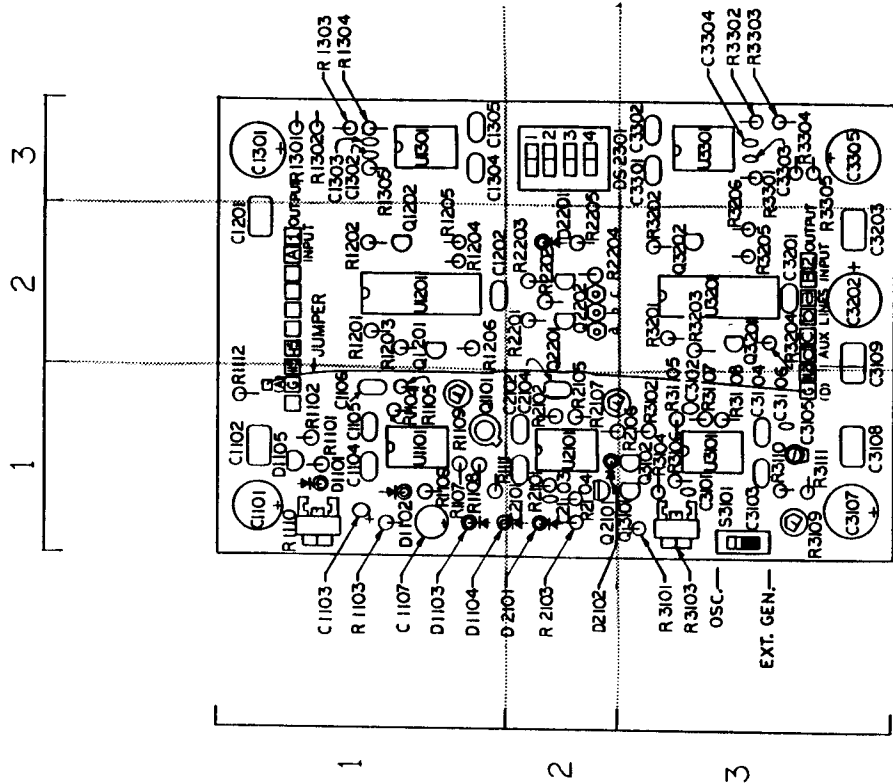

UNLESS OTHERWISE SPECIFIED DIMENSIONS ARE IN INCHES		CONTRACT NO.	
1	FRACTIONS DECIMALS ANGLES	DATE	8-10-87
2	1/2 1/4 3/8 1/2 3/4 1 1 1/2 2 3 4	APPROVALS	J.R.P.
3	1/8 1/16 1/32 1/64 1/128 1/256 1/512 1/1024 1/2048 1/4096 1/8192 1/16384 1/32768 1/65536 1/131072 1/262144 1/524288 1/1048576 1/2097152 1/4194304 1/8388608 1/16777216 1/33554432 1/67108864 1/134217728 1/268435456 1/536870912 1/1073741824 1/2147483648 1/4294967296 1/8589934592 1/17179869184 1/34359738368 1/68719476736 1/137438953472 1/274877906944 1/549755813888 1/1099511627776 1/2199023255552 1/4398046511104 1/8796093022208 1/17592186044416 1/35184372088832 1/70368744177664 1/140737488355328 1/281474976710656 1/562949953421312 1/1125899906842624 1/2251799813685248 1/4503599627370496 1/9007199254740992 1/18014398509481984 1/36028797018963968 1/72057594037927936 1/144115188075855872 1/288230376151711744 1/576460752303423488 1/1152921504606846976 1/2305843009213693952 1/4611686018427387904 1/9223372036854775808 1/18446744073709551616 1/36893488147419103232 1/73786976294838206464 1/147573952589676412928 1/295147905179352825856 1/590295810358705651712 1/1180591620717411303424 1/2361183241434822606848 1/4722366482869645213696 1/9444732965739290427392 1/18889465931478580854784 1/37778931862957161709568 1/75557863725914323419136 1/151115727451828646838272 1/302231454903657293676544 1/604462909807314587353088 1/1208925819614629174706176 1/2417851639229258349412352 1/4835703278458516698824704 1/9671406556917033397649408 1/19342813113834066795298816 1/38685626227668133590597632 1/77371252455336267181195264 1/154742504910672534362390528 1/309485009821345068724781056 1/618970019642690137449562112 1/1237940039285380274899244224 1/2475880078570760549798488448 1/4951760157141521099596976896 1/9903520314283042199193953792 1/19807040628566084398387907584 1/39614081257132168796775815168 1/79228162514264337593551630336 1/158456325028528675187103260672 1/316912650057057350374206521344 1/633825300114114700748413042688 1/1267650600228229401496826085376 1/2535301200456458802993652170752 1/5070602400912917605987304341504 1/10141204801825835211974608683008 1/20282409603651670423949217366016 1/40564819207303340847898434732032 1/81129638414606681695796869464064 1/162259276829213363391593738928128 1/324518553658426726783187477856256 1/649037107316853453566374955712512 1/129807421473370690713274991145024 1/259614842946741381426549982290048 1/51922968589348276285309996458016 1/103845937178696552570619992916032 1/207691874357393105141239985832064 1/415383748714786210282479971664128 1/830767497429572420564959943328256 1/1661534994859144841129919886656512 1/3323069989718289682259839773313024 1/6646139979436579364519679546626048 1/13292279958873158729039359093252096 1/26584559917746317458078718186504192 1/53169119835492634916157436373008384 1/106338239670985269832314872746016768 1/212676479341970539664629745492033536 1/425352958683941079329259490984067104 1/850705917367882158658518981968134208 1/1701411834735764317317037963936268416 1/3402823669471528634634075927872536832 1/6805647338943057269268151855745073664 1/13611294677886114538536303711490457328 1/2722258935577222907707260742298094656 1/5444517871154445815414521484596189312 1/1088903574230889163082904296919238624 1/2177807148461778326165808593838477248 1/4355614296923556652331617187676944496 1/8711228593847113304663234375353888992 1/1742245718769422660932646875070777984 1/3484491437538845321865293750141555968 1/696		