

BENCHMARK MEDIA SYSTEMS, INC.

RLY-106 Instruction Manual

1.0 Introduction.....	1
2.0 Input and Output Connections.....	1
2.1 Connection Alternatives.....	2
3.0 Relay Ratings	2
4.0 Applications.....	4
4.1 Audio Signal Polarity Inverter	4
4.2 Remote +48 V Microphone Phantom Power Switch	4
5.0 Circuit Description.....	5
6.0 Schematic Diagram.....	7

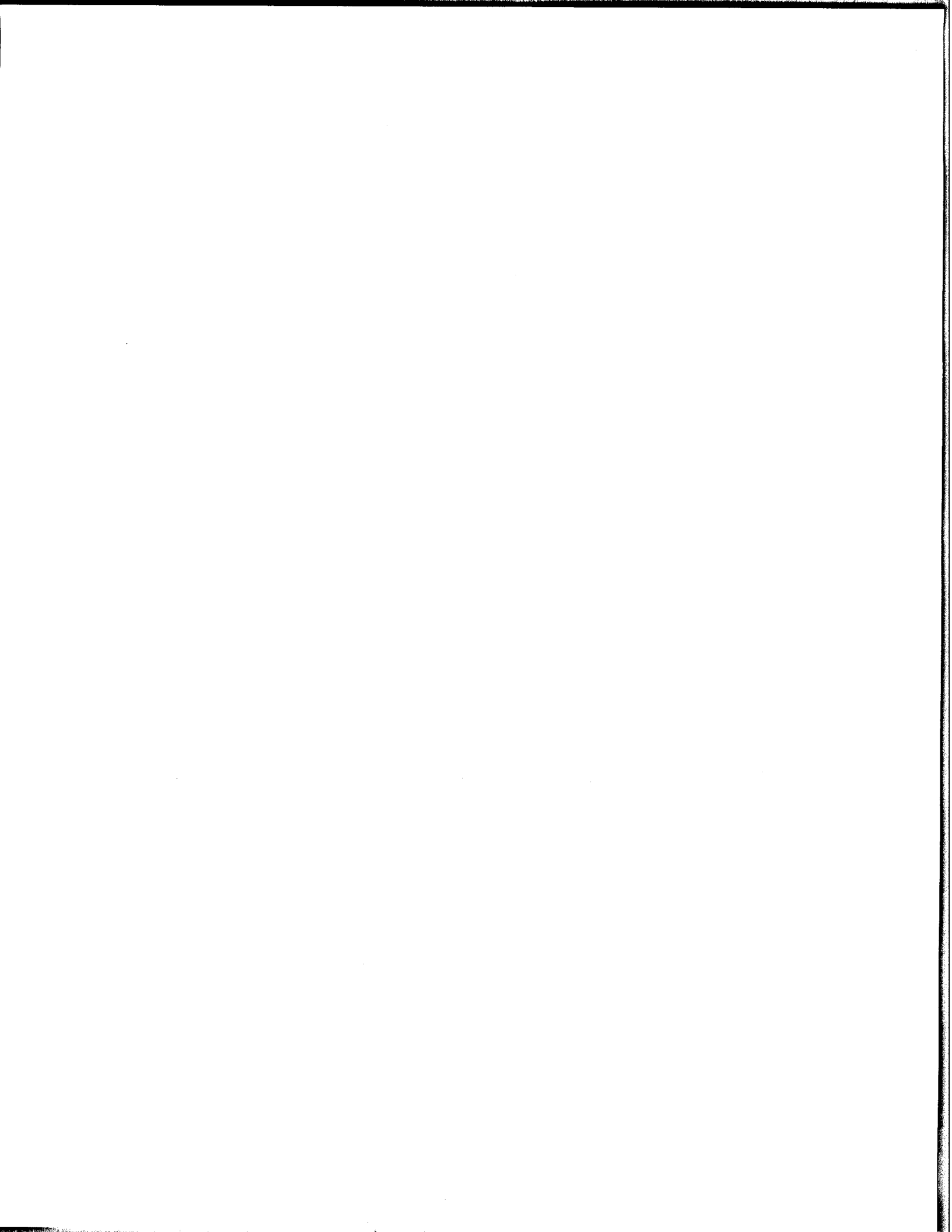

BENCHMARK MEDIA SYSTEMS, INC.

RLY-106 Instruction Manual

1.0 Introduction

The RLY-106 is an utility module for the Benchmark System 1000. It has six, double-pole double-throw, relays that allow remote control of numerous switching functions. It may be used to select between two different sources of audio, control DC circuits such as remote control of phantom power, implement audio polarity inversion, among other uses.

The RLY-106 requires a 12 volt input to actuate the relays. This is immediately available from the +12 volt digital power bus on the rear of the card frame. A red LED at the front edge of the module indicates the relays actuation state. With no actuation the LED is extinguished. The control inputs of the module are low current CMOS devices that have a 10 k Ω pull down resistor on their input and are diode protected to the Digital ground and +12 V power rails. 100 k Ω pull down resistors may be ordered special.

2.0 Input and Output Connections

Normally closed and normally open contact inputs are made by spanning a single three position Molex® SL™ connector horizontally across the card edge connector. Although *Shield* is normally connected to the center connector position with audio circuits, when spanning horizontally there is no center ground pin.

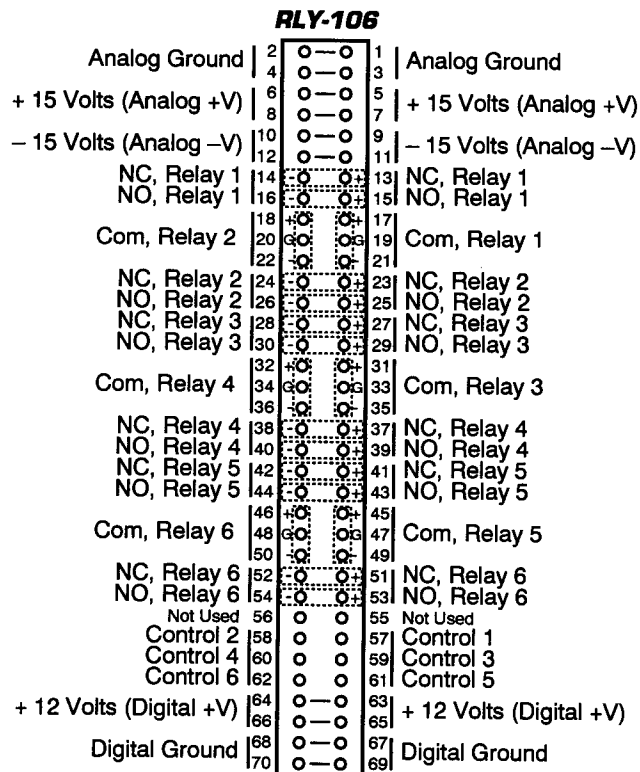

Figure 1 - Card Edge Connector Pinout

You must be sure that the shield connects to ground either at the other end of the pair or that a separate wire is taken to the Analog ground bus from the shielded pair.

The *Common* connections of the relay are made with the same three position SL housing, oriented vertically. Control inputs may be made using three 3 pin housings oriented horizontally, or by using two 3 pin housings vertically.

2.1 Connection Alternatives

The SIB-70, a plug in PCB that holds three rows of EuroStyle barrier strips, may be used as an alternative to the individual plug on Molex connectors. The barrier strips must be fully wired before insertion into the card edge connector shell at the rear of the MF-300 backplane.

A third option exists, in the plug on BRG-70, a 70 pin Berg mating connector, that must also be fully pre-wired before insertion onto the back of the card edge connector on the MF-300 backplane.

3.0 Relay Ratings

The RLY-106 uses very high quality reed relays that have precious metal contacts and are excellent for switching audio and DC with high reliability. Under normal use the contact

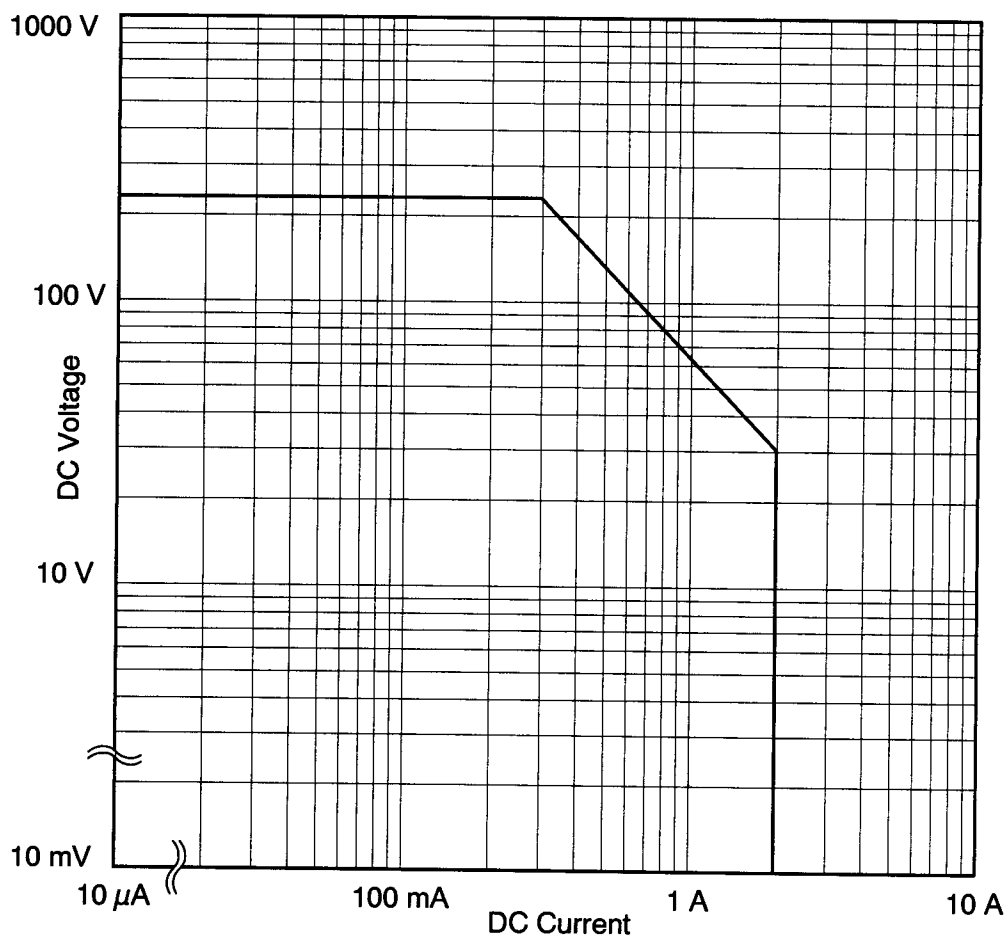

Figure 2 - Maximum Relay Switching Power (Resistive Load)

ratings of the relay allow a life of well over three million operations.

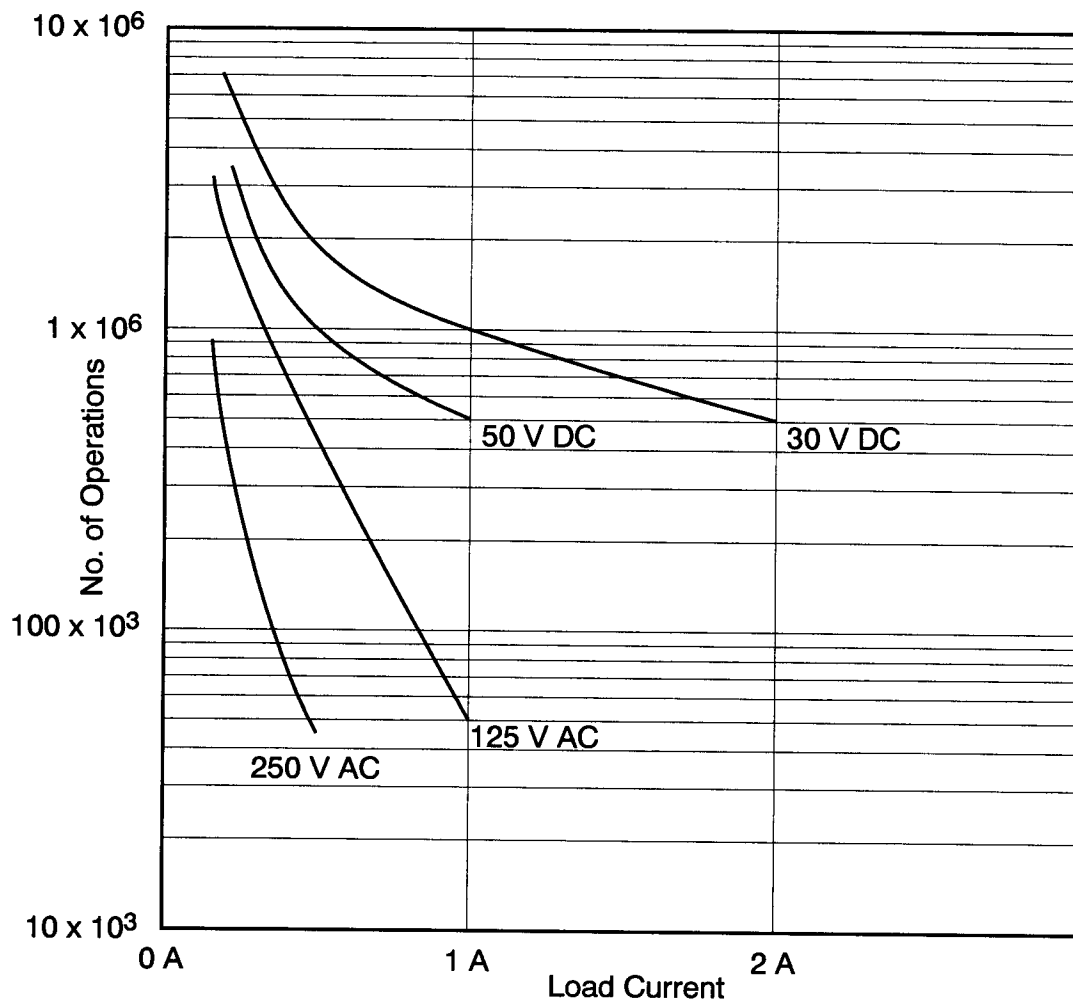

Figure 3 - Relay Life Curve (Resistive Load)

Specific published ratings of the relay are as follows:

Contact material	Gold-clad silver
Contact Ratings (resistive)	
Maximum switching power	60 W, 125 VA
Maximum switching current	2A AC or DC
Maximum carrying current	3A AC or DC
Maximum switching voltage	220 VDC, 250 VAC
Minimum contact rating	10 μ A @ 10 mVDC
UL/CSA rating	
	0.6 A @ 125 VAC
	0.6 A @ 110 VDC
	2 A @ 30 VDC
Minimum life (Max load)	
operations-electrical	5x10 ⁵ (2A 30 VDC)
	2x10 ⁶ (1A 30 VDC)

operations-mechanical

10⁸

Breakdown voltage
(between open contacts)

1000 V RMS min.
1500 V surge

4.0 Applications

Two useful applications of the RLY-106 will now be described.

4.1 Audio Signal Polarity Inverter

The need often arises for inverting the polarity (often incorrectly called phase) of a balanced audio signal. This is especially easy since jumpers have been included on the printed circuit board to eliminate the need to make additional external connections. These jumpers are W11 and W12 for relay one, W21 and W22 for relay two, etc. See Figure 4.

Audio should be brought into the RLY-106 on the *Normally Closed* contacts and taken to it's destination from the *Common* contacts. With the jumpers in place, actuating the relay will provide an audio polarity inversion.

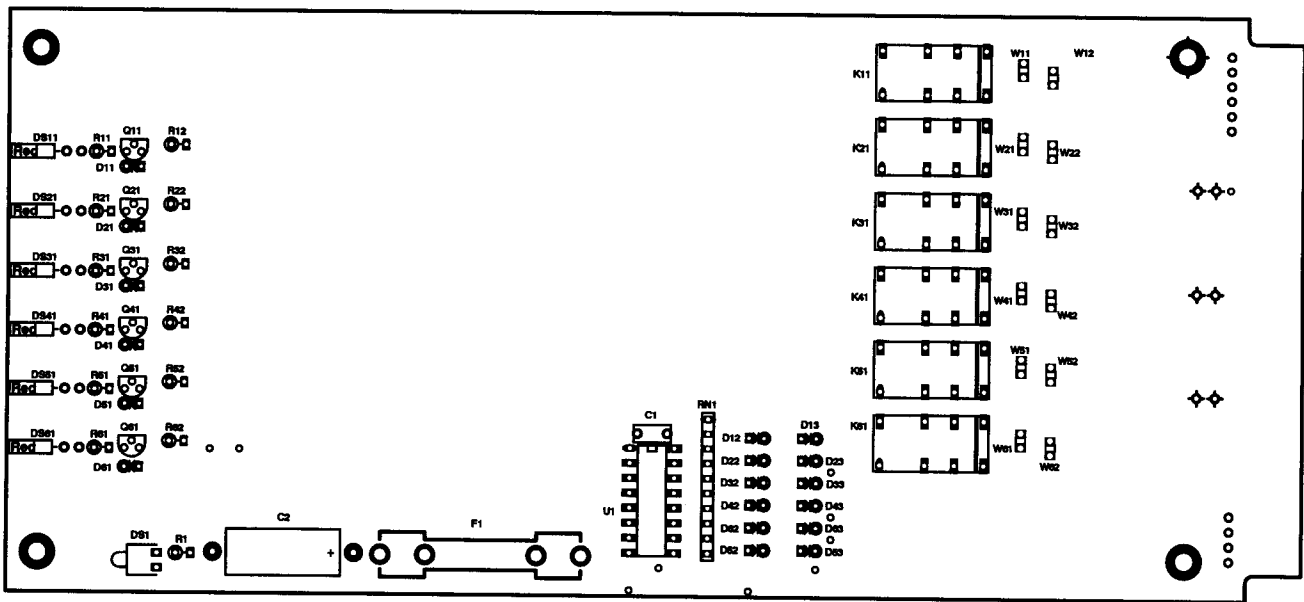

Figure 4 - PCB Layout

!!! Warning !!!

If the module is not to be used for polarity inversion, jumpers W11 through W62 must be removed since they will interfere with the intended use of the relay and may cause a short circuit to potentially destructive currents.

4.2 Remote +48 V Microphone Phantom Power Switch

The MDA-101 and MDA-102 microphone preamplifier DA modules have as an option, remotely controllable gain in the form of the RGC-03/04 remote gain daughterboard modules. Additionally, they have a remotely controllable input attenuator, however, they do not have remotely controllable phantom power. The circuit shown in Figure 5 will

control the phantom power to the module. Two RLY-106 modules will control 10 MDA-101s with two circuits left for other use such as polarity inversion. The 470 Ω resistor is included to reduce the discharge rate of the filter capacitor on the MDA modules. Also please note that the circuit will turn on *both* channels of phantom power on the MDA-102; there is no way to separate the two channel's power.

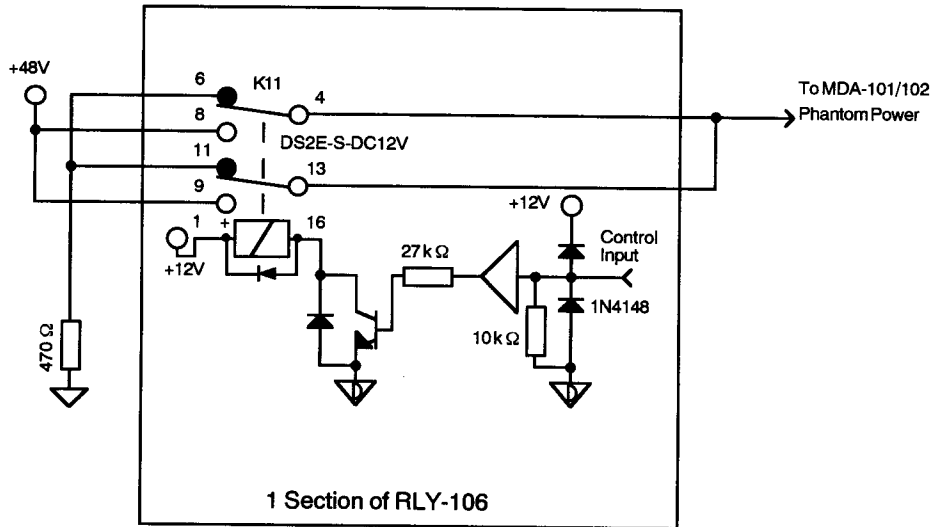

Figure 5 - Wiring for Phantom Power Control

5.0 Circuit Description

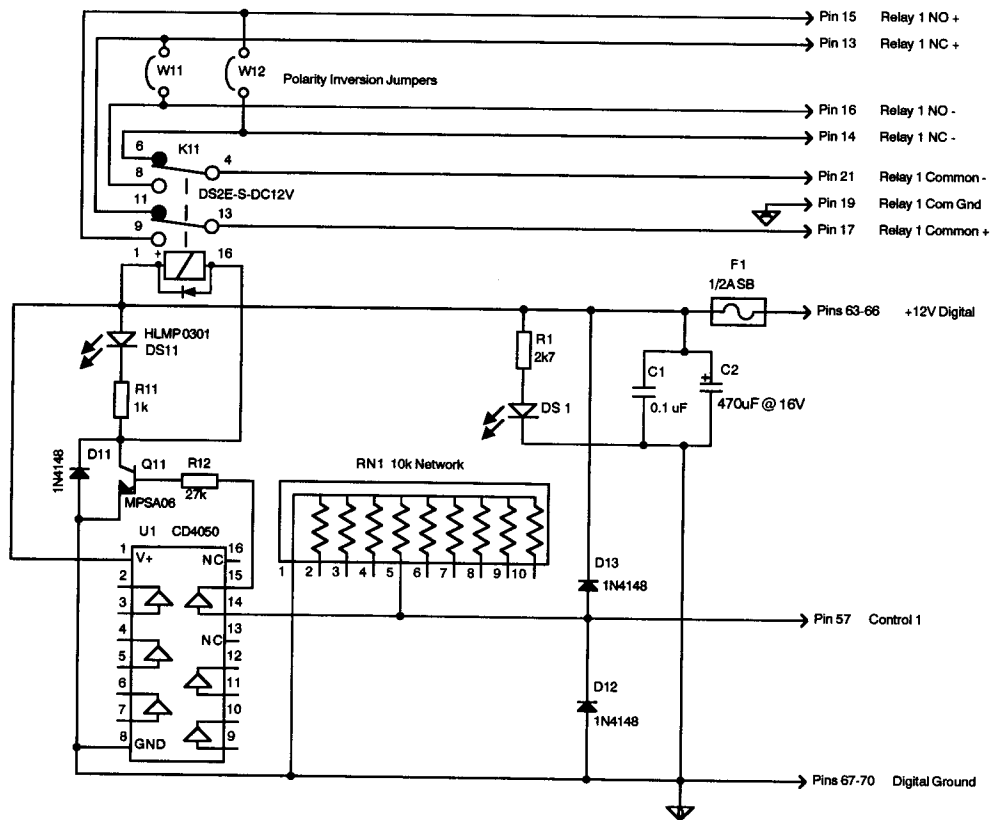

Figure 6 - Simplified Channel Schematic.

The circuit is extremely simple and requires little explanation. The only significant point to note is the input impedance of the control circuit. The input impedance is set by the pull down resistor single-in-line-pack. As shipped, these resistors are 10 k Ω . This value was chosen in the interest of noise immunity. However, this resistance may be too low for some control circuits, in which case a 100 k Ω package may be substituted. Please contact the factory for more information on this modification.

This completes the RLY-106 instruction manual.

053194

BENCHMARK MEDIA SYSTEMS, INC.
5925 Court Street Road
Syracuse, NY 13206-1707
Phone 315-437-6300, FAX 315-437-8119

REVISIONS

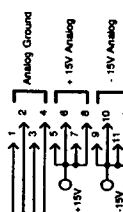
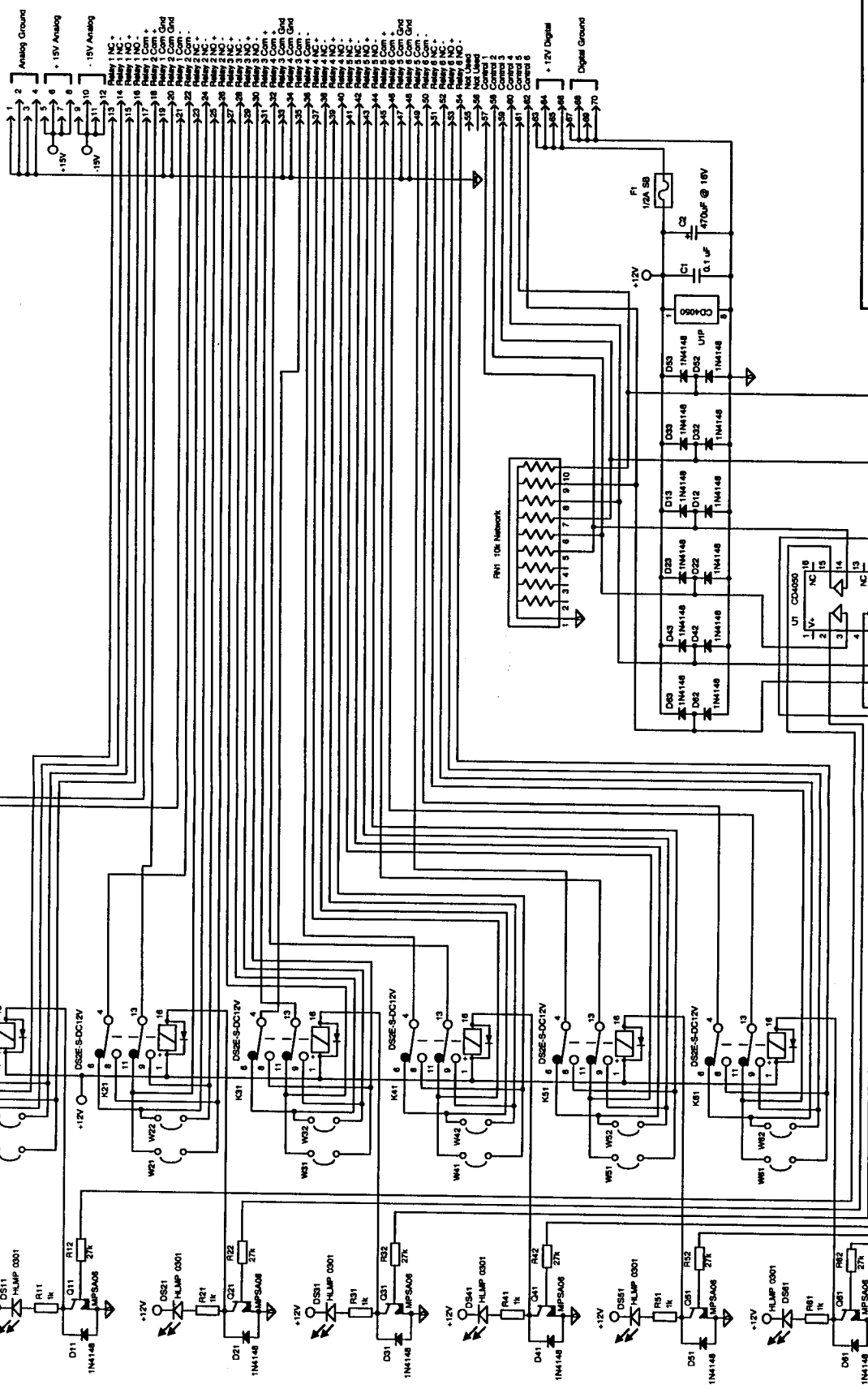

BENCHMARK MEDIA SYSTEMS, INC.

RLY-106

DATE: 8/15/83
 DRAWN BY: R.W. Webb
 CHECKED BY: [Blank]
 PART NO.: 480127

C SCHEMATIC

